

<b>ISSUE:</b>	<b>DRAWN BY:</b>	<b>CHECKED BY:</b>	<b>CRF No:</b>	<b>DATE:</b>	<b>DESCRIPTION:</b>
a	LE	KB	2699	05/05/22	First Issue
b	LE	KB	2786	18/08/22	Removed TUV label + amended eye icon information (P.3)
c	SJ	KB	3243	04/06/24	Added FS310 x 2
d	SJ	KB	3418	06/02/25	Added Custom 2024-
e					
f					
g					
h					
i					
j					
k					
l					
m					

# TS11YR TowStep

## Instructions

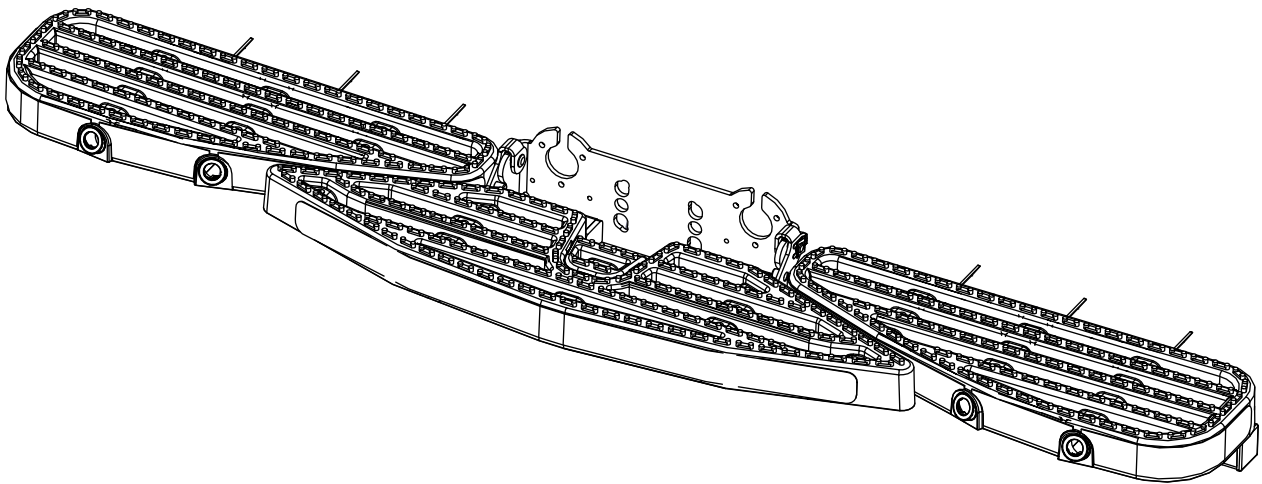

**TS11YRFI:**

**CITROEN** Dispatch 2019-, Relay/Jumper 2006-  
**FIAT** Ducato 2006-  
**FORD** Transit 2014-, Custom 2012-2018, 2024-  
**IVECO** Daily 2014-  
**MAN** TGE 2017-  
**MAXUS** Deliver9 2020-  
**MERCEDES** Sprinter 2018-  
**PEUGEOT** Boxer 2006-, Expert 2019-  
**RENAULT** Master 2010-, Trafic 2014-  
**TOYOTA** Proace 2019-  
**VAUXHALL/OPEL** Movano 2010-, Vivaro 2014-  
**VW** Crafter 2017-, T5/T6 2015-

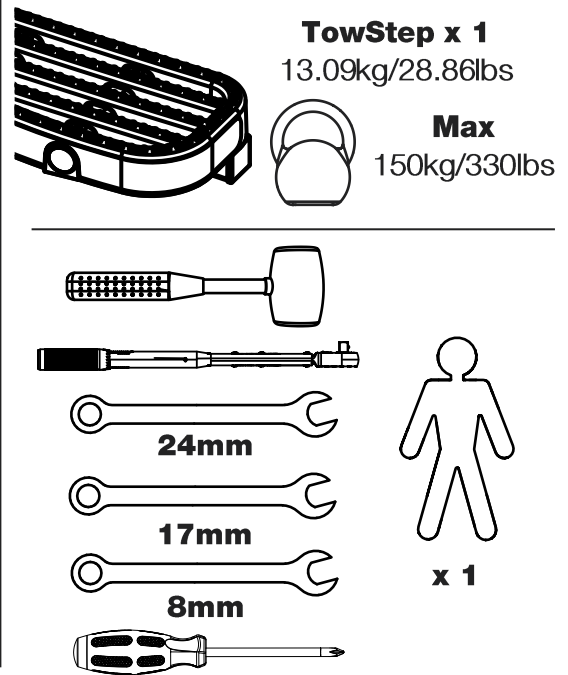

**TowStep**

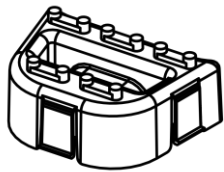

PS508 x 1

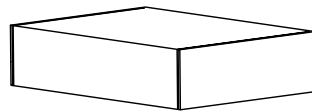

RSA001 x 1

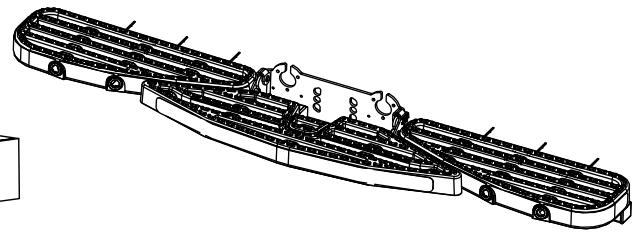

TS11YR x 1

**Fitting Kit**



FS140 (M5 x 16) x 3

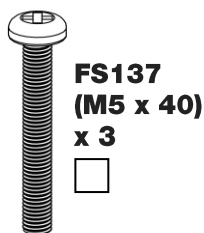

FS137 (M5 x 40) x 3

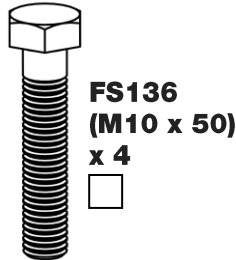

FS136 (M10 x 50) x 4

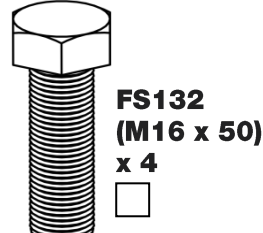

FS132 (M16 x 50) x 4

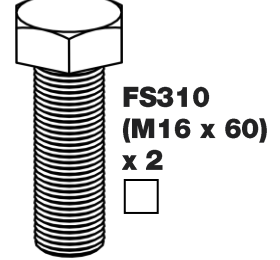

FS310 (M16 x 60) x 2



FN045 (M10) x 4



FN043 (M16) x 4

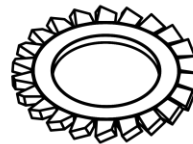

FW023 (M10) x 4

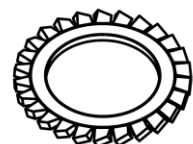

FW024 (M16) x 4



FN029 (M5) x 6

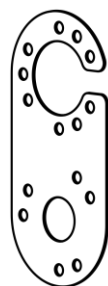

MS504 x 1

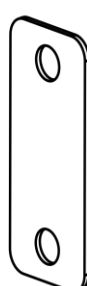

MS1150 x 1 (Dixon Bate Only)









PS502 (6mm) x 4

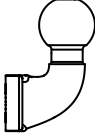
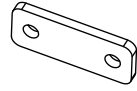
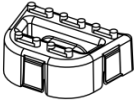
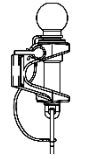
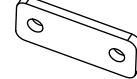

PS503 (16mm) x 4

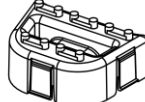
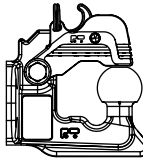
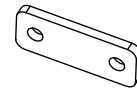
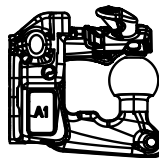
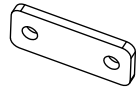
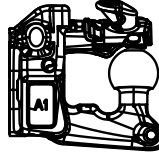
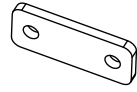
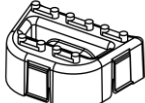
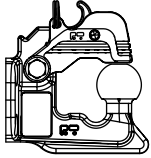
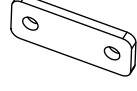
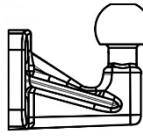
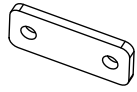

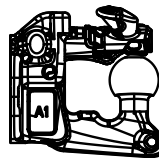
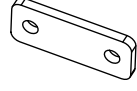
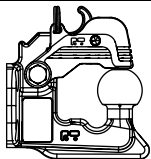
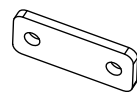
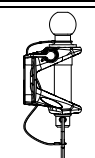
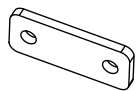
<b>M16 x 2</b>	Standard 50mm Tow Ball		<b>MS1150</b> ✗ 	
	Bradley Ball & Pin (185080815)		<b>MS1150</b> ✗ 	<b>PS508</b> ✓
	Dixon Bate (185002015)		<b>MS1150</b> ✓  3b. 	
	Crochet à boule 70C (2905019)		<b>MS1150</b> ✗ 	<b>PS508</b> ✗
	MULTIS - Crochet à boule mixte (2905080)		<b>MS1150</b> ✗ 	✗
<b>M16 x 4</b>	MULTIS - Crochet à boule mixte (2905083)		<b>MS1150</b> ✗ 	
	Crochet à boule 70C (2905024)		<b>MS1150</b> ✗ 	<b>PS508</b> ✗
<b>M10 x 4</b>	Universal 4 Hole Flange		<b>MS1150</b> ✗ 	
	MULTIS - Crochet à boule mixte (2905081)		<b>MS1150</b> ✗ 	<b>PS508</b> ✗
	Crochet à boule 70C (2905022)		<b>MS1150</b> ✗ 	✗
	Euro 4 Bolt & Pin (185075015)		<b>MS1150</b> ✗ 	<b>PS508</b> ✓



**A. M10 x 4**

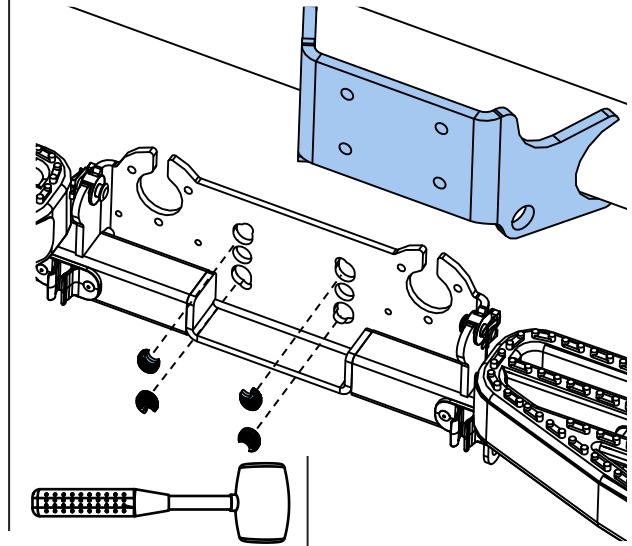
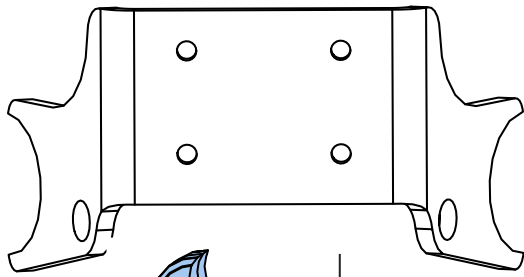

**B. WITTER**

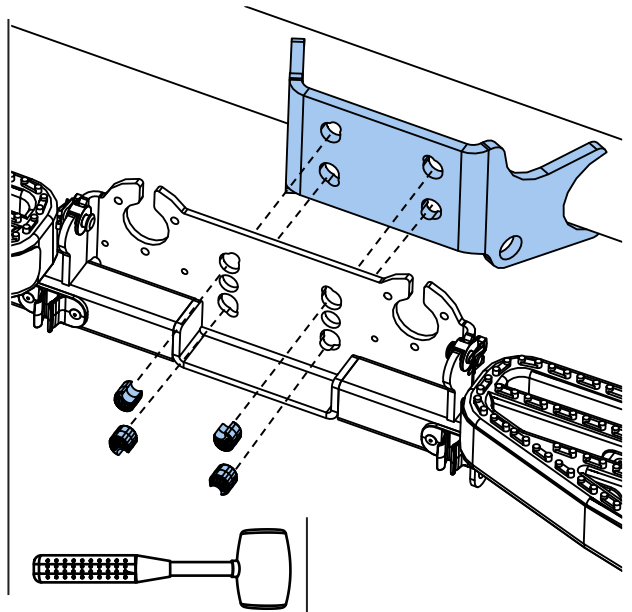
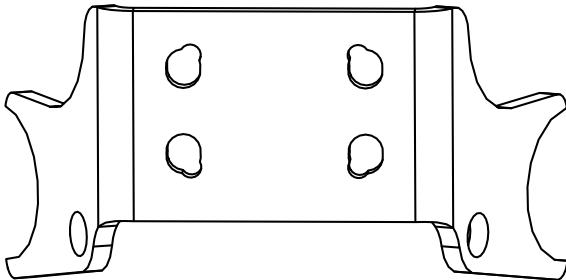

**C. M16 x 4**

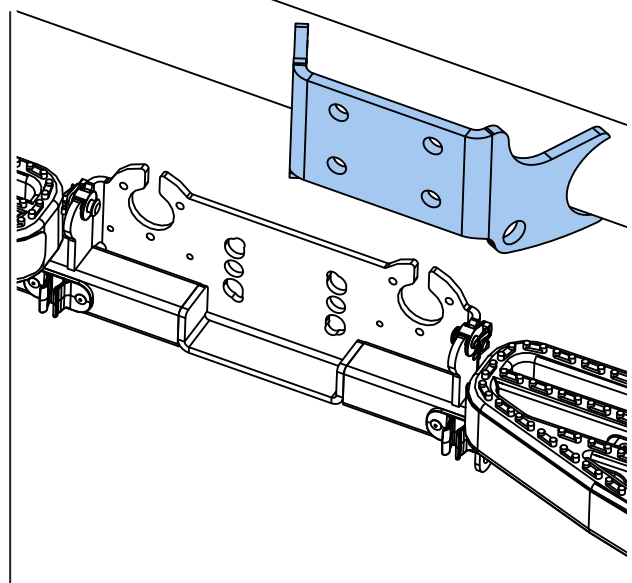
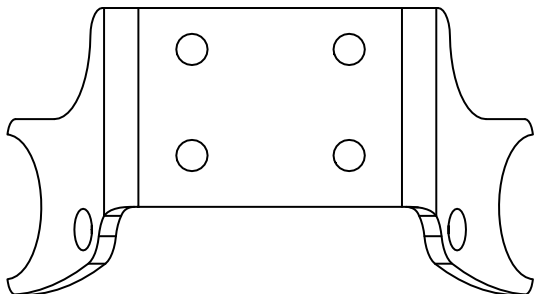

1.

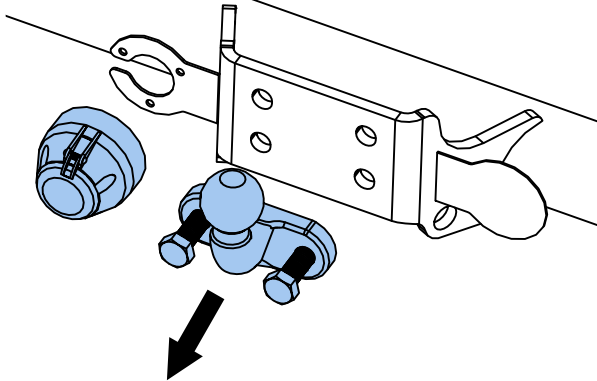

2.

M16 x 50/60    M10 x 50

FS132/  
FS310

FW024

FN043

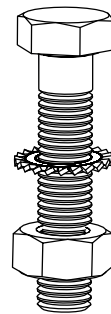
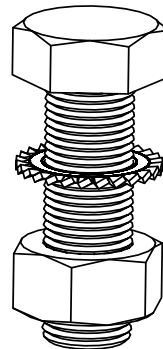

FS136

FW023

FN045

3a.

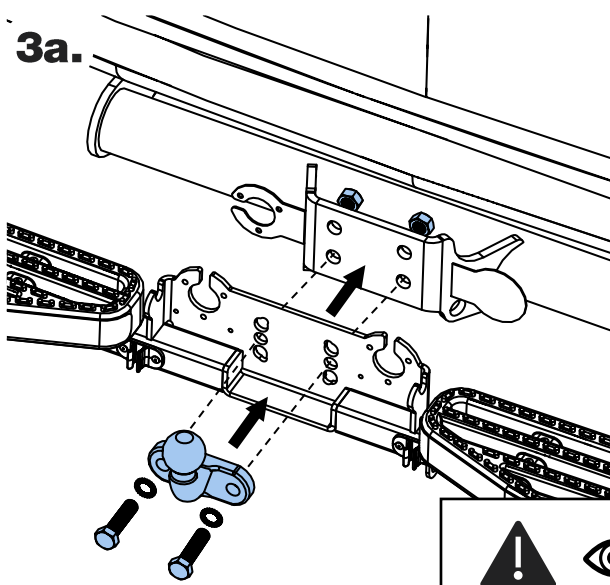

3b.

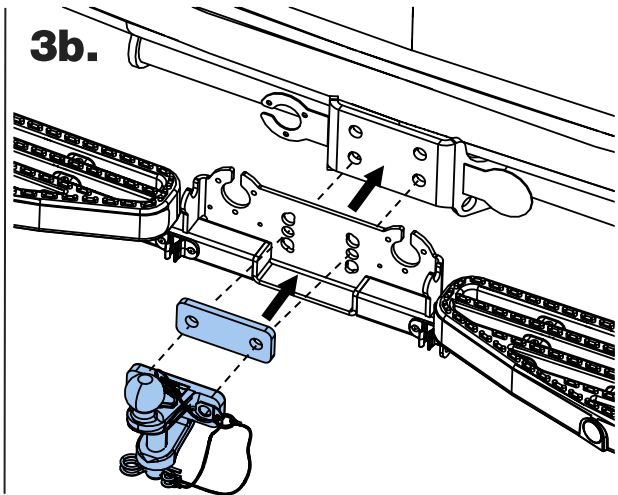

P.3

(Dixon Bate Only)

4.

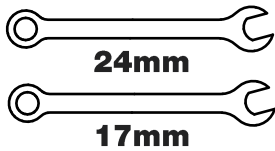
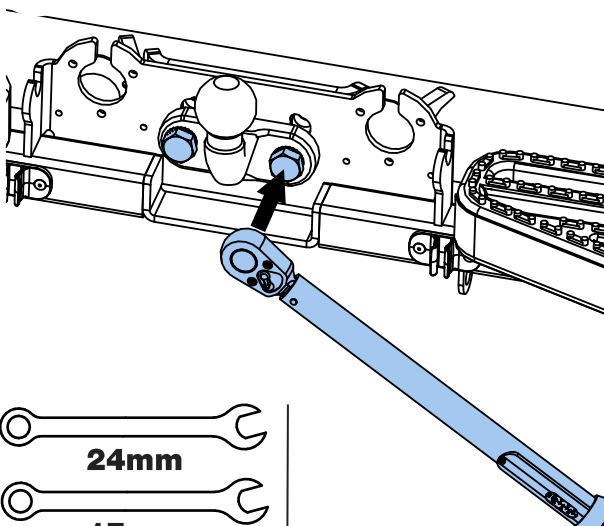

5.

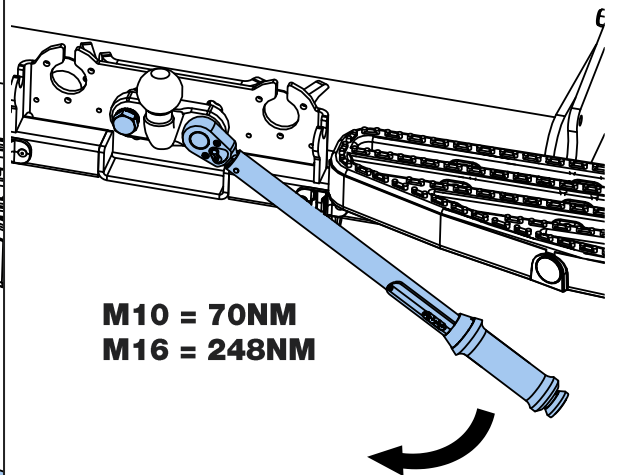

M10 = 70NM  
M16 = 248NM

6.

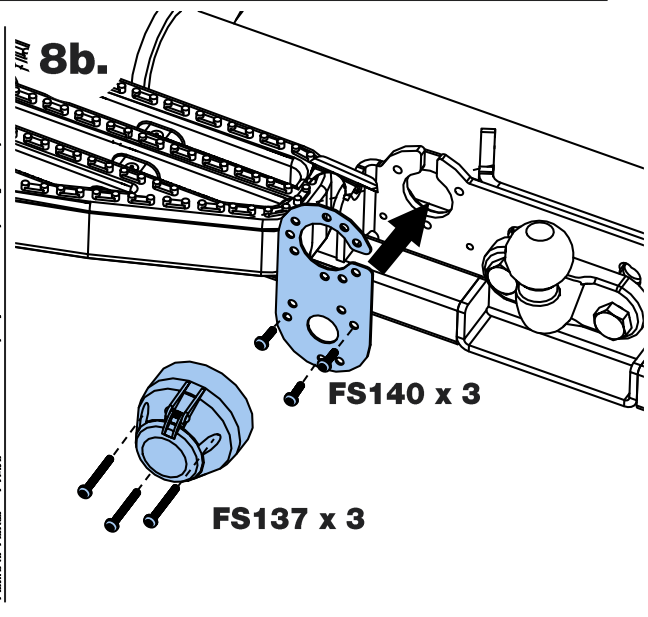
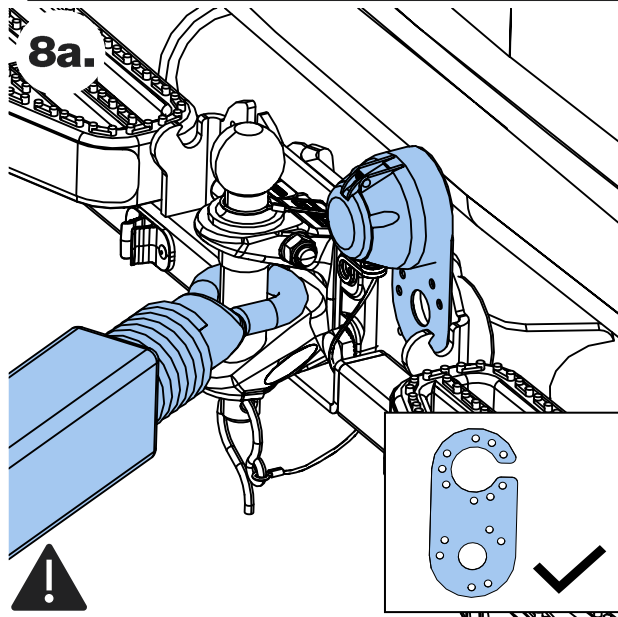
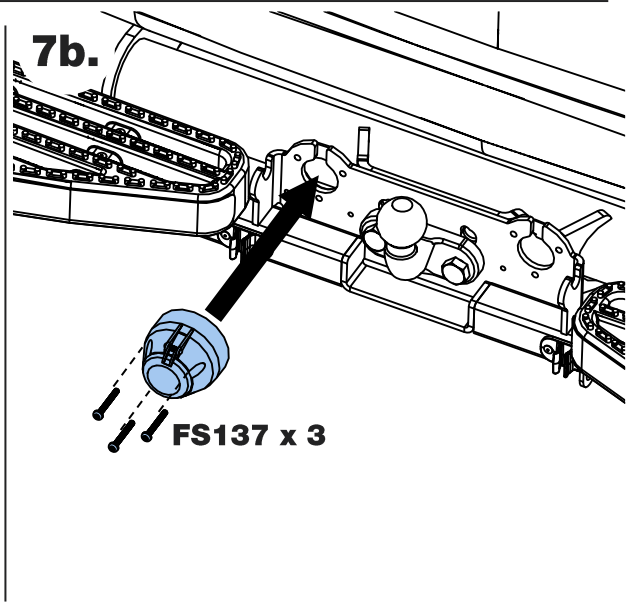
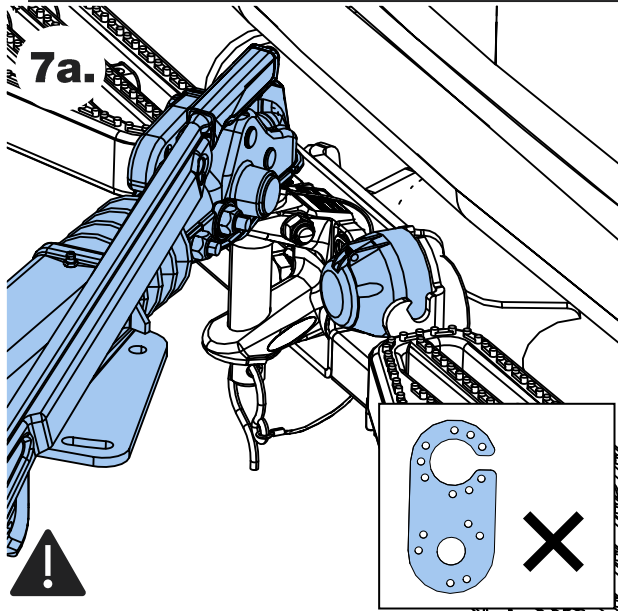
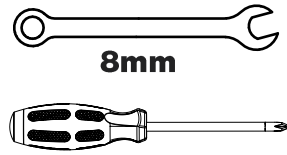
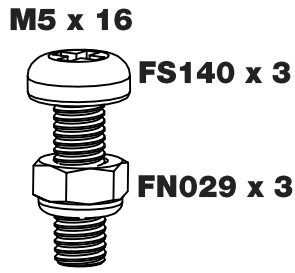
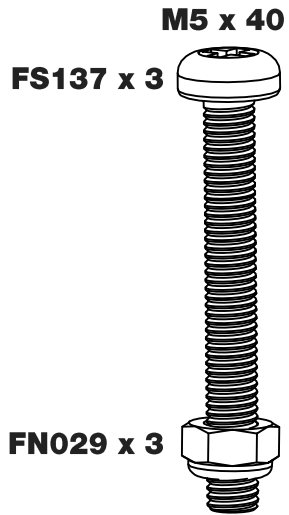

9.

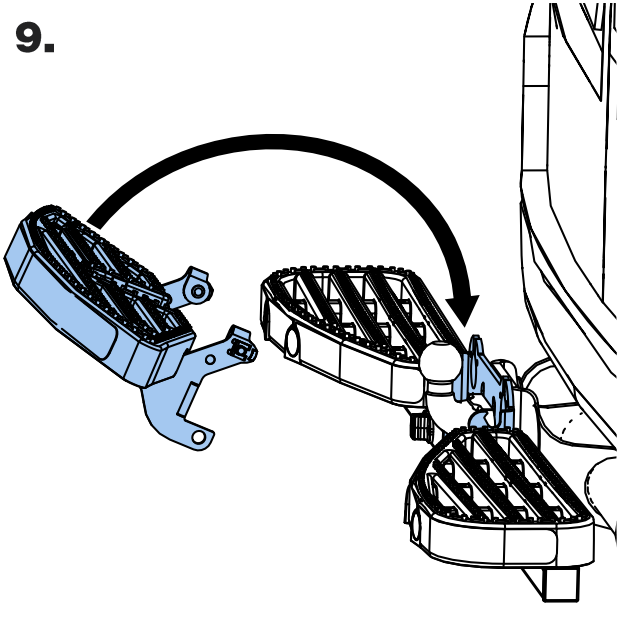

10.

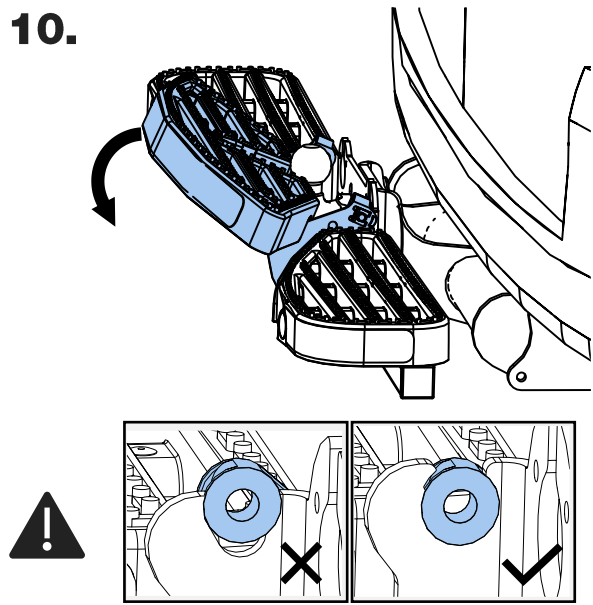

11.

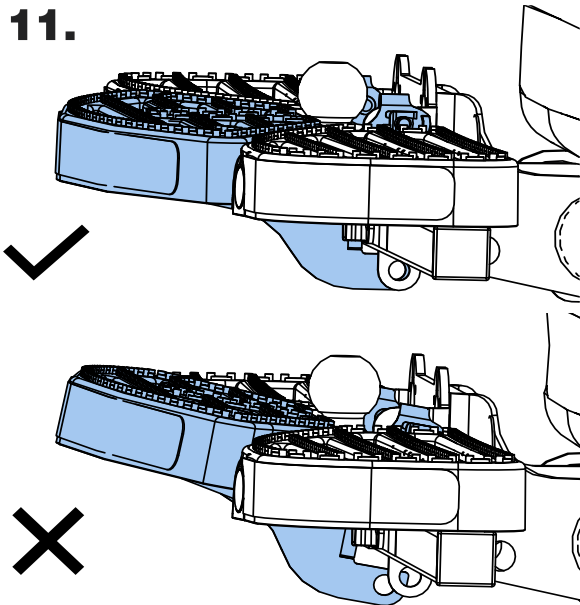

12.

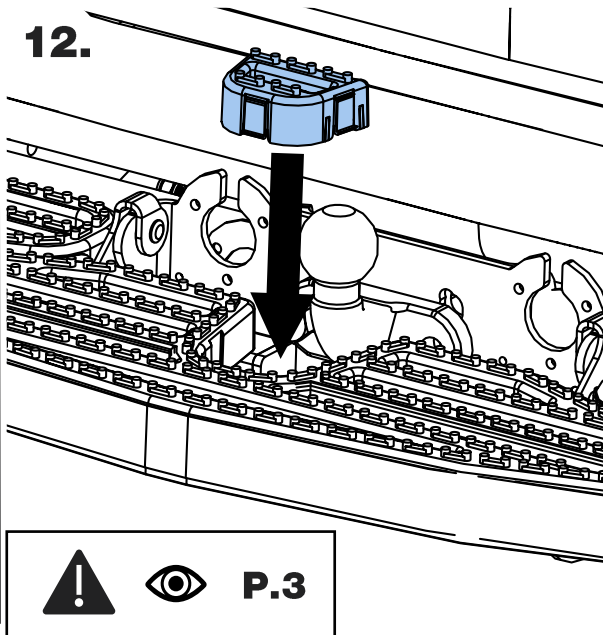

13.

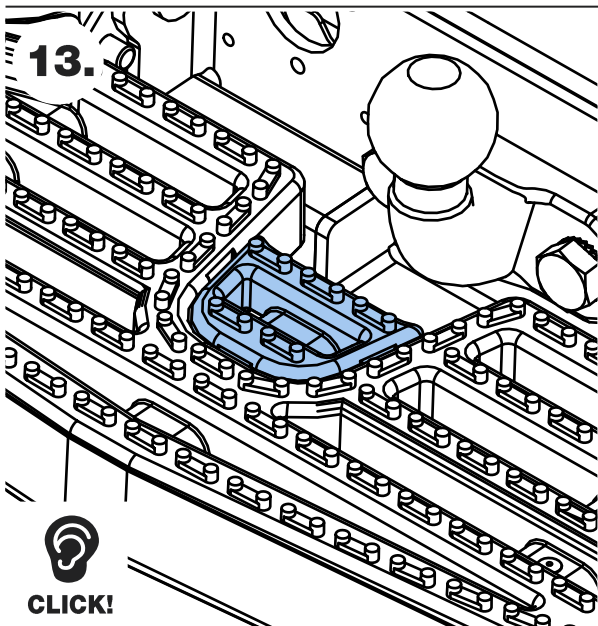

14.

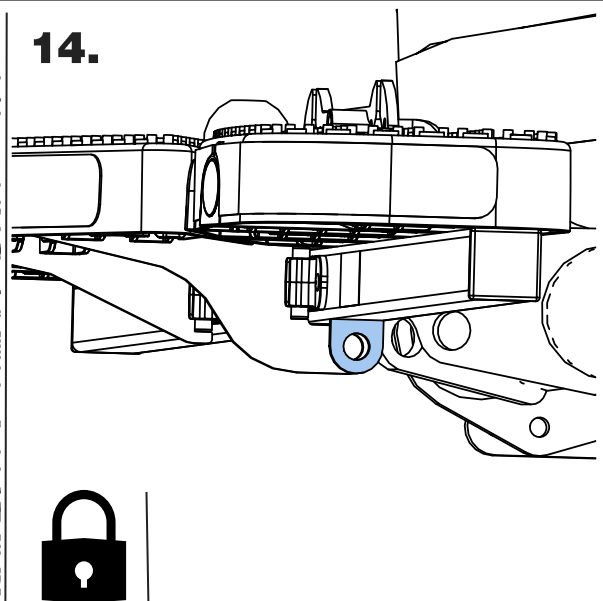

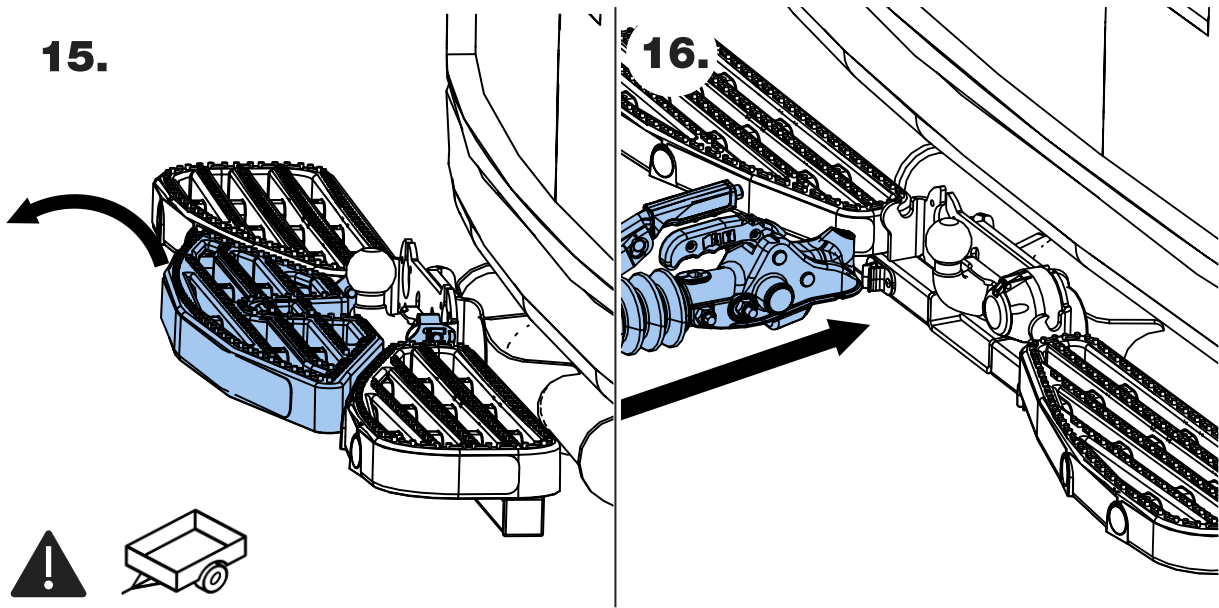

**17.**

**RSA001**

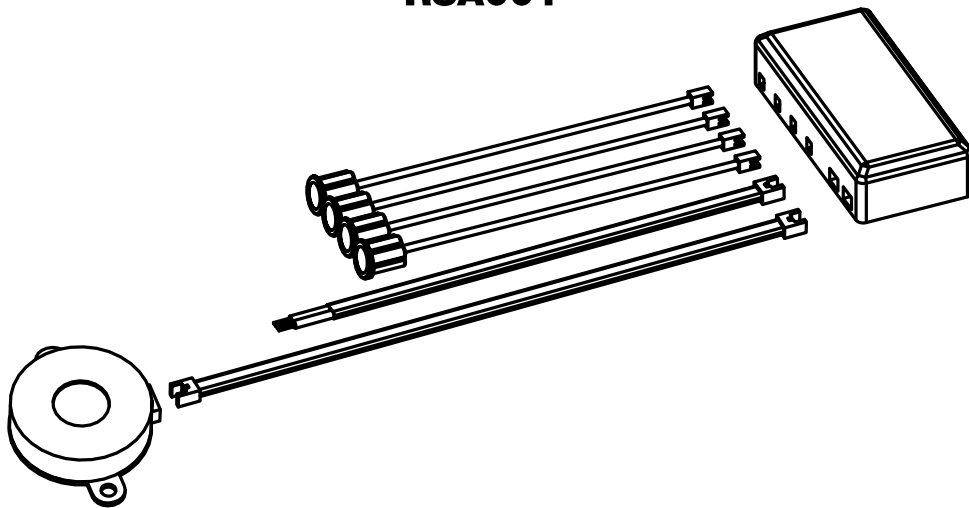

**18a.**

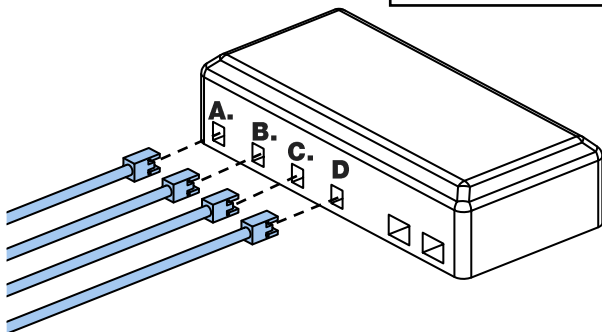
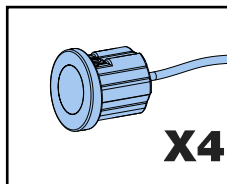

**18b.**

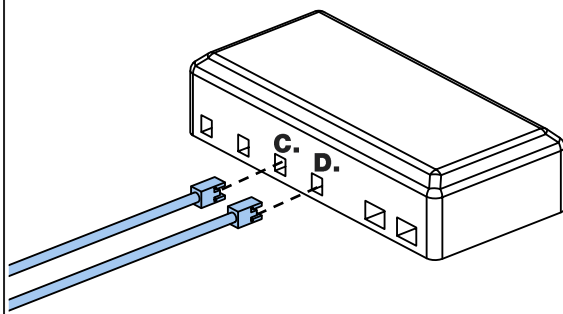
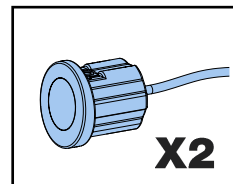

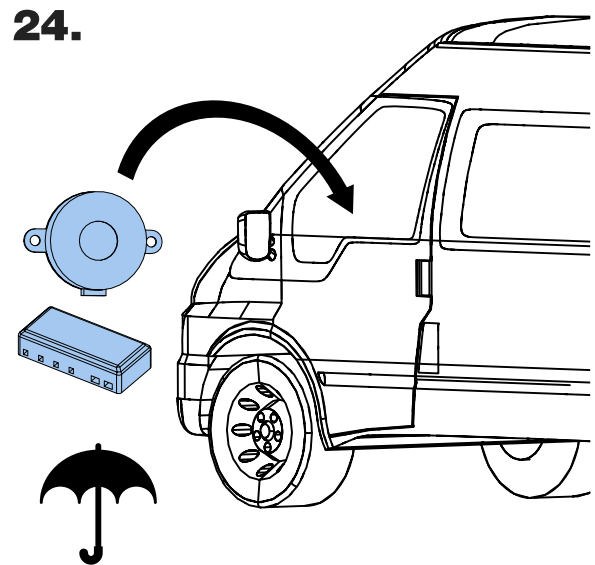
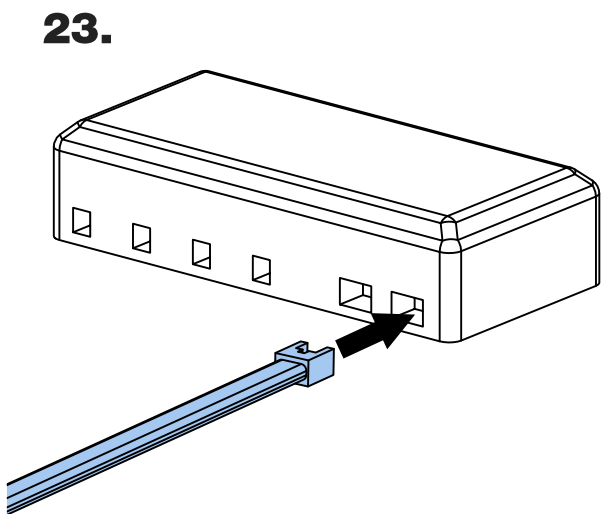
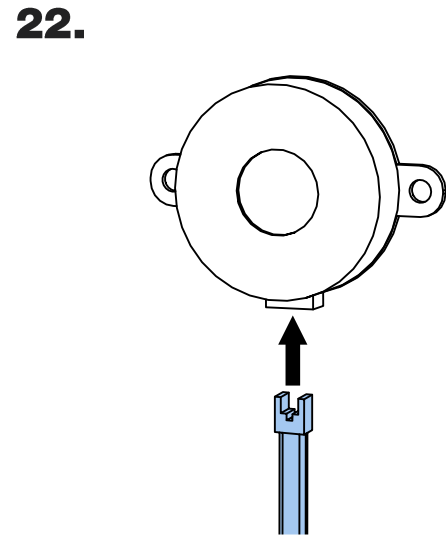
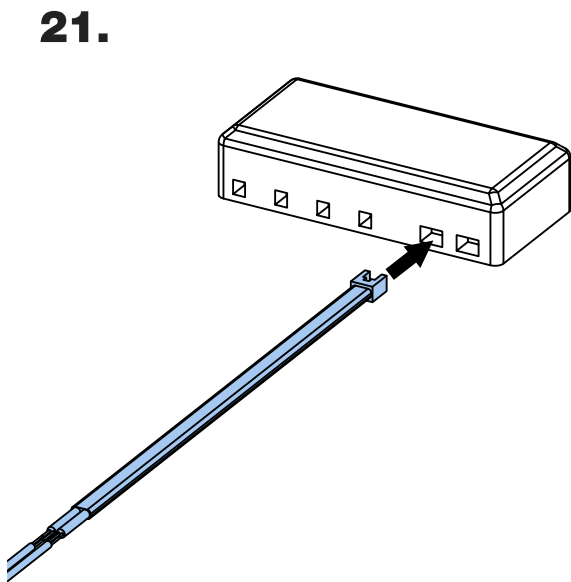
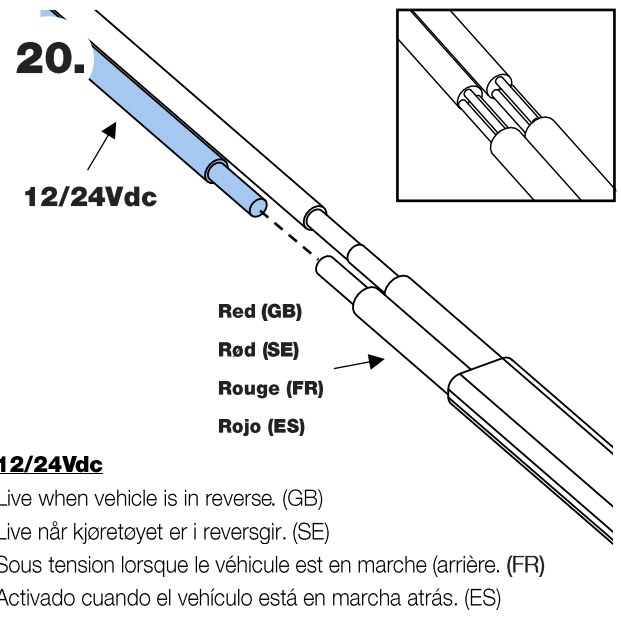
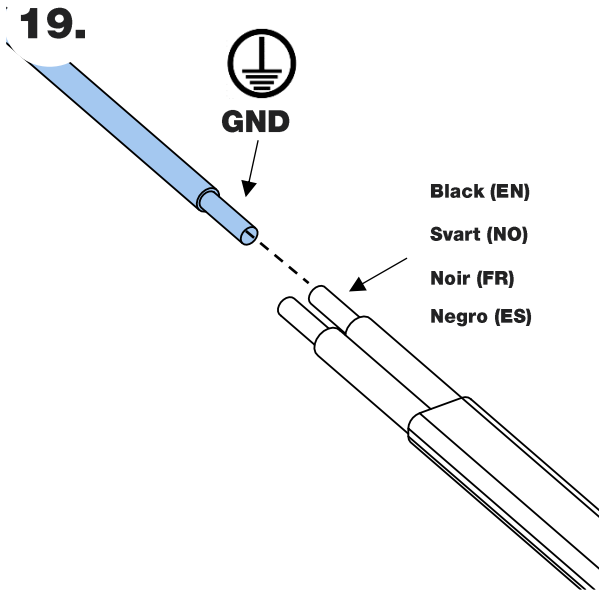

**Technical information (GB)****Key Features**

- 4 Sensor Audible Kit
- Towbar Intelligent (Dip switch 1 rear of ECU control unit)
- Sensor height adjustable 45cm-55cm
- Self-Test function
- 21mm Sensors
- 4&2 sensor option
- 2 eye – use C & D on the ECU control unit
- Buzzer size: 42 x 16mm

**Technical Specifications**

- Operating voltage range: 12/24 volt
- Ultrasonic frequency: 40KHz
- Control Working temperature: -30 - +70 °C
- Detection Range: 0.2 – 1.5m
- Rated Current: 20-200mA

**Switch 1:** The system will not alarm if there is a towbar and spare tyre in the back side of the vehicle.

**Switch 2:** Distance control function shortens the detection distance of sensor A&D to 1M which is 20cm shorter than the original distance. The buzzer alarms the rear distance between obstacles and Towbar / spare tyre, instead of distance between obstacle and bumper.

**Teknisk informasjon (SE)****Viktige funksjoner**

- 4-sensors hørbart sett
- Tilhengerfeste, intelligent (dippbryter 1 bak ECU-kontrollenhet)
- Sensorhøyde justerbar 45 cm - 55 cm
- Selvtestfunksjon
- 21 mm sensorer
- 4&2 sensoralternativ
- 2 maljer – bruk C & D på ECU-kontrollenheten
- Alarmstørrelse: 42 x 16mm

**Tekniske spesifikasjoner**

- Driftsspenningsområde: 12/24 volt
- Ultrasonisk frekvens: 40KHz
- Kontroll driftstemperatur: -30 - +70 °C
- Deteksjonsområde: 0,2 – 1,5 m
- Nominell spenning: 20-200 mA

**Bryter 1:** Systemet vil ikke avgi alarm hvis det er et tilhengerfeste og reservedekk på baksiden av kjøretøyet.

**Bryter 2:** Avstandskontrollfunksjonen forkorter deteksjonsavstanden til sensor A&D til 1M, som er 20 cm kortere enn den opprinnelige avstanden. Alarmen varsler bakre avstand mellom hindringer og tilhengerfestet / reservedekket, i stedet for avstanden mellom hindring og støtfanger

**Informations techniques (FR)****Principales caractéristiques**

- Kit sonore à 4 capteurs
- Barre d'attelage connectée (Commutateur Dip à l'arrière de l'unité de commande ECU)
- Hauteur de capteur réglable de 45 à 55 cm
- Fonction d'auto-test
- Capteurs 21 mm
- Option de 4 et 2 capteurs
- 2 capteurs – utilisent C et D sur l'unité de commande
- Taille d'avertisseur : 42 x 16 mm

**Fiche technique**

- Plage de tension de service : 12/24 volts
- Fréquence ultrasonique : 40 KHz
- Température utile de commande : -30 à +70 °C
- Plage de détection : 0,2 à 1,5 m
- Intensité nominale : 20 à 200 mA

**Commutateur 1:** Le système ne déclenche pas d'alarme si une barre d'attelage et une roue de secours se trouvent sur l'arrière du véhicule.

**Commutateur 2:** La fonction de contrôle de distance réduit la distance de détection des capteurs A et D à 1 m, à savoir 20 cm de moins que la distance initiale. L'avertisseur émet une alarme basée sur la distance arrière entre un obstacle et la barre d'attelage/roue de secours, au lieu de la distance entre l'obstacle et le pare-chocs.

**Información técnica (ES)****Características clave**

- Kit acústico de 4 sensores
- Función inteligente para enganche de remolque (interruptor DIP 1 en la parte posterior de la unidad de control ECU)
- Sensor de altura ajustable 45-55 cm
- Función de autodiagnóstico
- Sensores de 21 mm
- Opción de 4 y 2 sensores
- 2 sensores – uso de C y D en la unidad de control ECU
- Tamaño de indicador acústico: 42 x 16 mm • Taille d'avertisseur : 42 x 16 mm

**Características técnicas**

- Campo de tensiones de trabajo: 12-24 V
- Frecuencia ultrasonora: 40 kHz
- Temperatura de trabajo del controlador: -30 °C / 70 °C
- Campo de detección: 0,2-1,5 m
- Intensidad nominal: 20-200 mA

**Interruptor 1:** El sistema no activa la alarma cuando hay un enganche para remolque y una rueda de repuesto en la trasera del vehículo.

**Interruptor 2:** La función de control de distancia reduce la distancia de detección de los sensores A y D a 1 m, lo que es 20 cm menor que la distancia original. El indicador acústico de alarma se activa en función de la distancia entre un posible obstáculo y el enganche para remolque / la rueda de repuesto, en lugar de la distancia entre el obstáculo y el paragolpes.