

VECTA BAR™ Fitting Instructions





4 Bar Roof Kit– Volkswagen Crafter & MAN TGE L3H2 [2017 onwards]

4 Bar Kit: VC4VFK

Roof Bar	QTY	Checked
	4	<input type="checkbox"/>

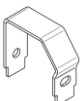



Total Weight: 7.048 Kg

Top Hat Kit

Item per bar	QTY per bar	Number of TH Kits per bar:
Top Hat 1 	2	<input type="text"/>
M8 x 80 	2	TH KIT COMPLETED BY: _____
M8 x 20 	4	
M8 	2	

TH Kit Weight: 0.29 Kg (per bar)







Load Stop Kit

Item	QTY	Checked
Load stop 	4	<input type="checkbox"/>
Crown 	4	<input type="checkbox"/>
M6 x 40 	4	<input type="checkbox"/>
Spanner 	1	<input type="checkbox"/>

LOAD STOP KIT COMPLETED BY: _____

LS Kit Weight: 0.38Kg







Foot Pack Kit 1

Item	QTY	Checked
46 – NS1 	1	<input type="checkbox"/>
46 – OS1 	1	<input type="checkbox"/>
Rubber 11 	2	<input type="checkbox"/>
M8 x 25 	2	<input type="checkbox"/>
M8 x 25 	2	<input type="checkbox"/>
M8 x 30 	2	<input type="checkbox"/>
M8 	2	<input type="checkbox"/>

FOOT PACK COMPLETED BY: _____

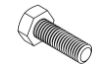
Foot Pack Weight: TBD

Foot Pack Kit 2

Item	QTY	Checked
46 – NS5+ 	3	<input type="checkbox"/>
46 – OS5+ 	3	<input type="checkbox"/>
Rubber 1 	6	<input type="checkbox"/>
M8 x 25 	6	<input type="checkbox"/>
M8 x 25 	6	<input type="checkbox"/>
M8 x 30 	6	<input type="checkbox"/>
M8 	6	<input type="checkbox"/>

FOOT PACK KIT COMPLETED BY: _____

Foot Pack Weight: TBD

8 - 15 Mins



All times are approximate from Hubb Systems testing and kit dependant

13 mm



13 mm



MAX 75 1/2 KG



MAX 77 KG



Subject to your Vehicle Handbook Guidelines

!



Please follow these instructions carefully and thoroughly to ensure that your product functions correctly

DATE PACKED: _____

ORDER PACKED BY: _____

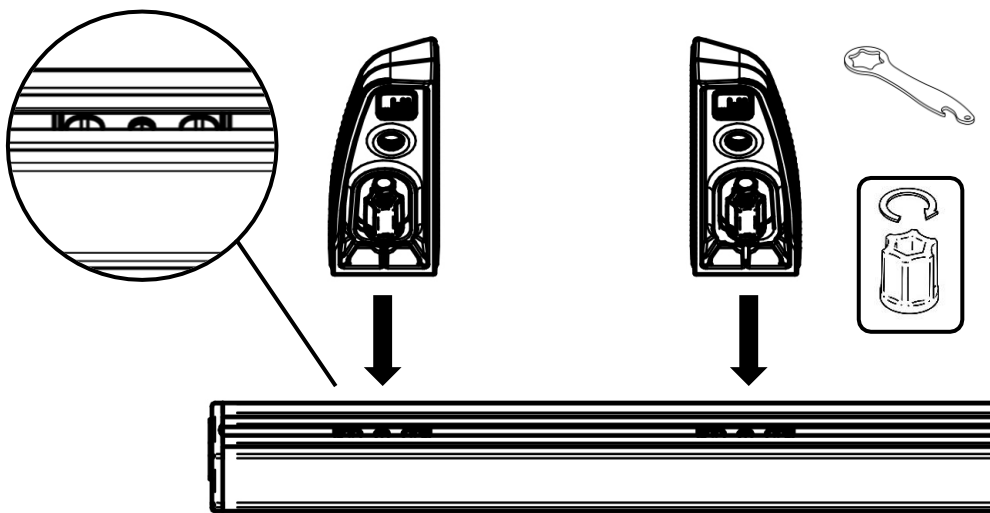

1

NOTE: 46-N/OS5+ bracket(s) are used on fixing points from 5 onwards. It is up to the user to decide which fixing points to use depending on the number of roof bars.

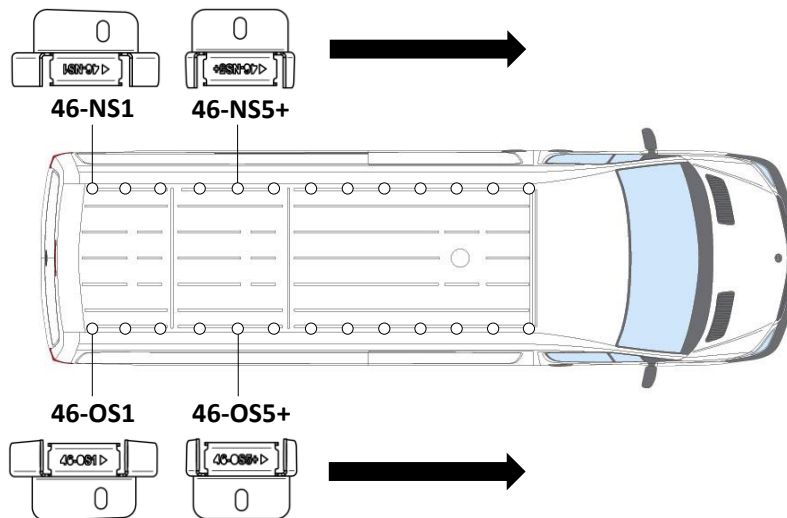

2

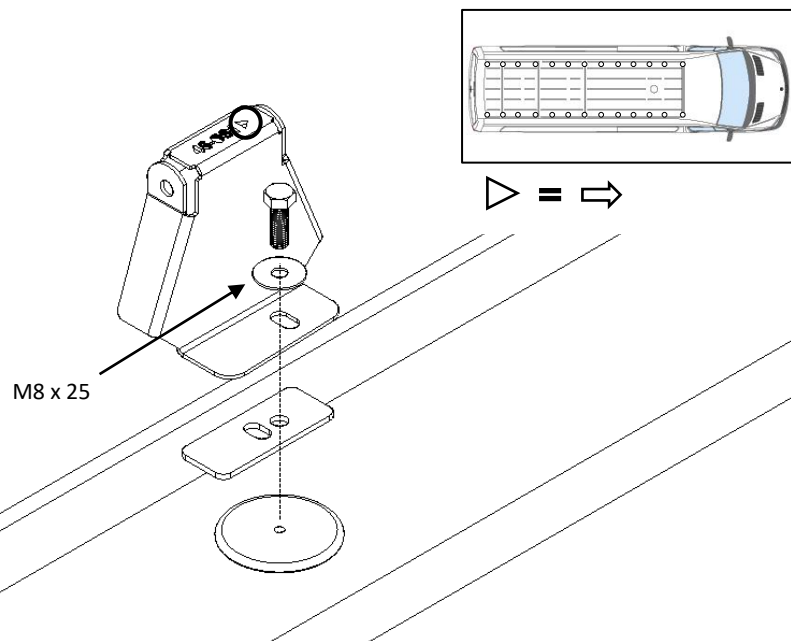

3

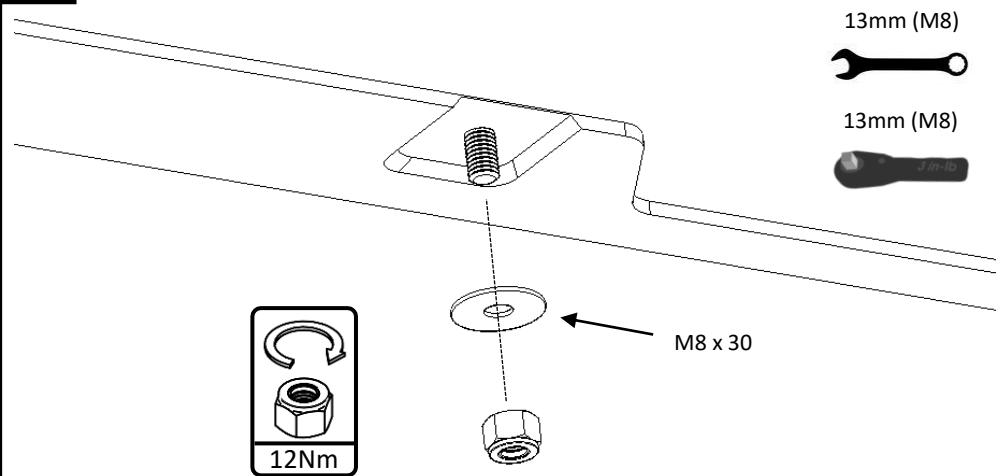

4

13mm (M8)

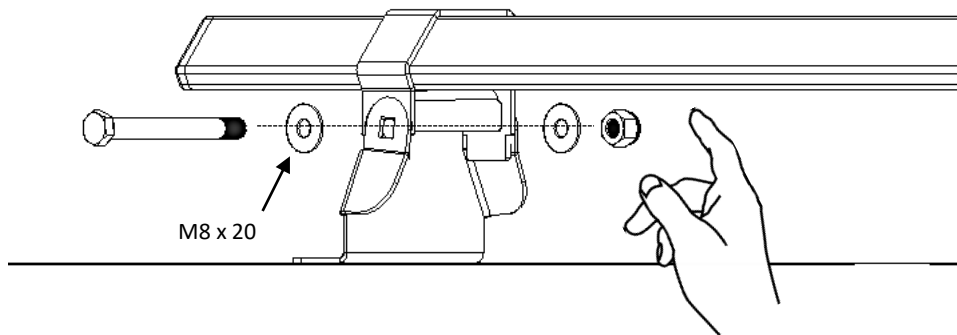

M8 x 20

5

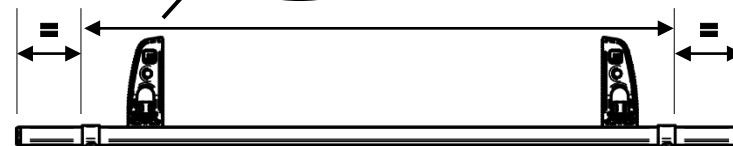
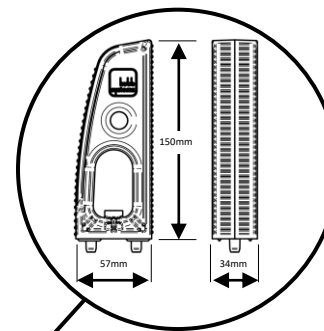

6

13mm (M8)



13mm (M8)

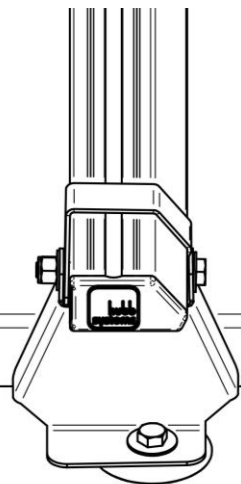

12Nm