

FM309-3FI

MR4

Instructions

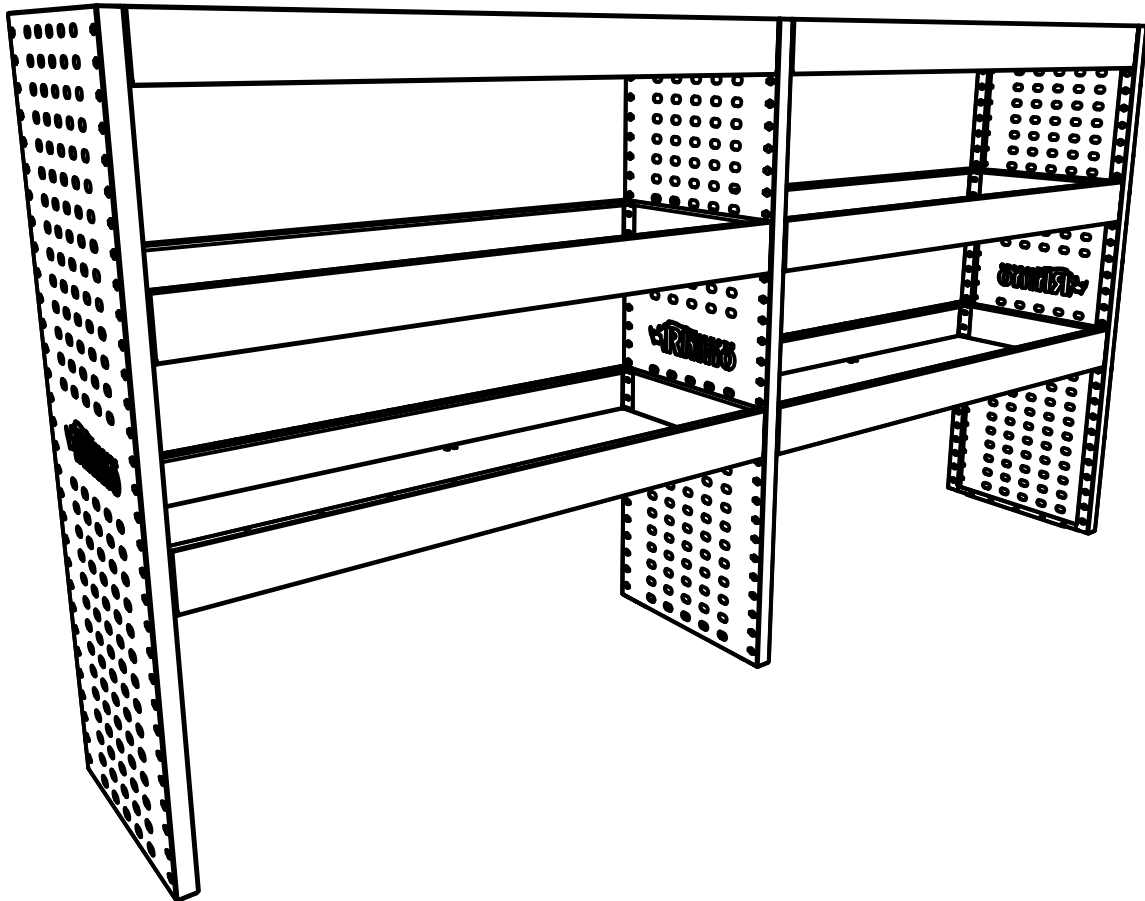

CRASH TESTED

According to ISO/ PAS 11154:2006



FORD TRANSIT CUSTOM (2023-) L1-H1

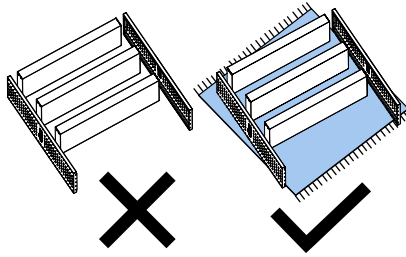

(U2)

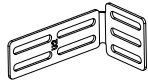

MS1986
x 4



(UP)

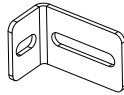

MS1988
x 4

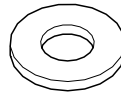

FW011
(M6 x 20)

x 9

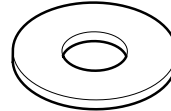

FW103
(M8 x 20)

x 18

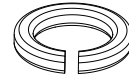

FW020
(M8) x 18

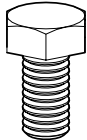

FS075
(M8 x 20mm)

x 6

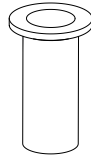

FN079
(M8) x 12

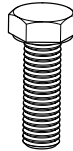

FB006
(M8 x 30mm)

x 12

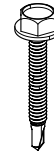

FS296
(M5.5 x 35mm)

x 9

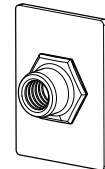

SA518
(M8) x 6

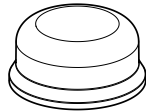

PS414
(M8) x 18

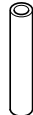

PS570
(4mm) x 1

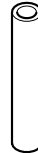

PS571
(9mm) x 1

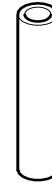

PS599-01
(13mm) x 1



	Please only drill in advised locations. Rhino Products Ltd will not accept liability for incorrect fitment.
	Bohren Sie bitte nur an den angegebenen Stellen. Die Rhino Products Ltd. übernimmt keinerlei Haftung für falsche Montage.
	Percer uniquement aux endroits précisés. Rhino Products Ltd décline toute responsabilité en cas de montage incorrect.
	Forare solo nelle posizioni consigliate. Rhino Products Ltd non si assume alcuna responsabilità in caso di montaggio errato.
	Taladre sólo en los puntos indicados. Rhino Products Ltd no aceptará ninguna responsabilidad de un montaje incorrecto.
	Otwory należy wiercić tylko we wskazanych miejscach. Firma Rhino Products Ltd nie ponosi odpowiedzialności za nieprawidłowy montaż.
	Boor alleen op aanbevolen plaatsen. Rhino Products Ltd aanvaardt geen enkele aansprakelijkheid voor onjuiste montage.
	Kérem, csak a javasolt helyeken végezzen fúrást. A hibás szerelésért a Rhino Products Ltd nem vállal felelősséget.
	Borra bara på anvisade ställen. Rhino Products Ltd tar inget ansvar för felaktigt montage.
	Vrtejte prosím pouze na doporučených místech. Společnost Rhino Products Ltd nepřijme odpovědnost za nesprávnou montáž.
	Poraa vain ilmoitettuihin kohtiin. Rhino Products Ltd ei ole vastuussa virheellisestä asennuksesta.
	Bor kun på de angitte stedene. Rhino Products Ltd vil ikke påta seg ansvar for feil montering.
	Vrtajte iba v odporučanih mestih. Spoločnosť Rhino Products Ltd nenesie zodpovednosť za nesprávnu montáž.

2.



3.



4.



5.



6.



7.



8a.

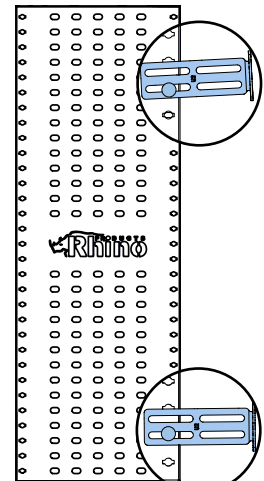
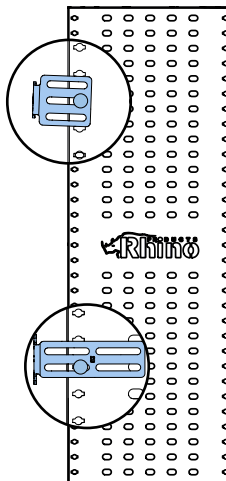
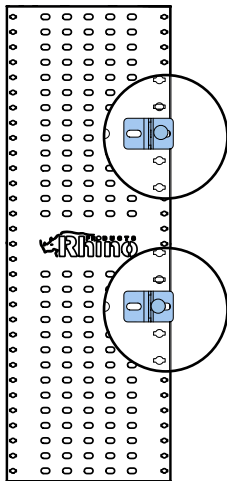
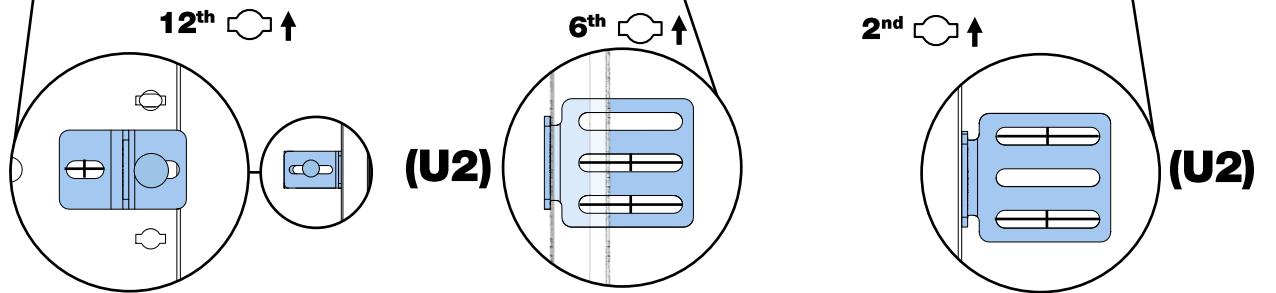
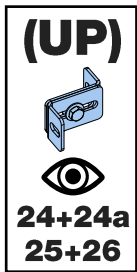
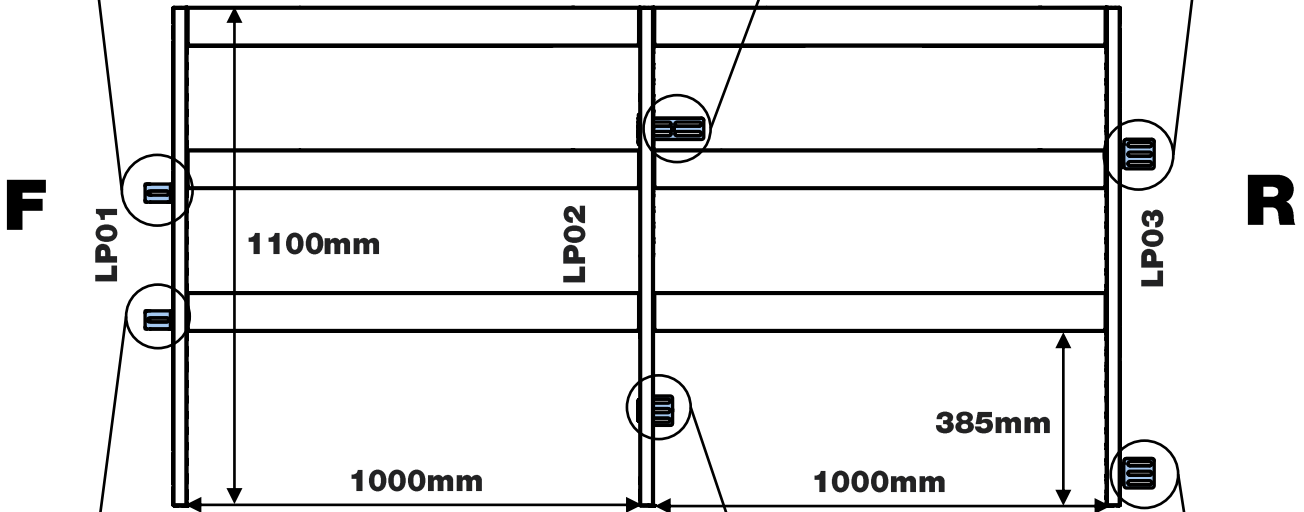
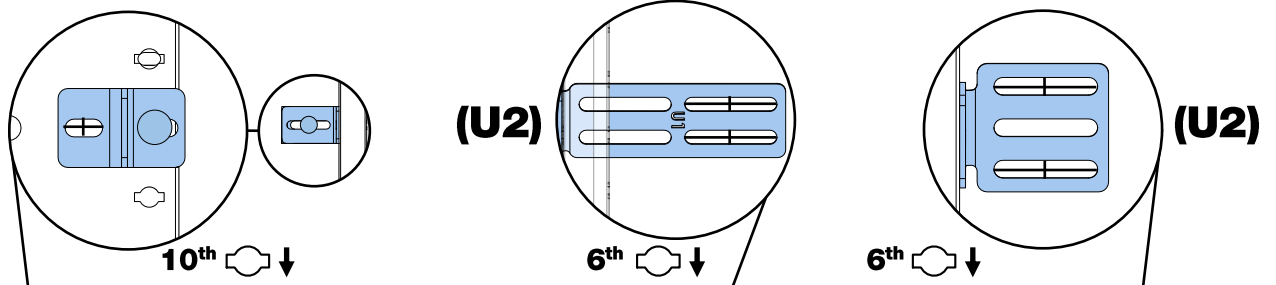
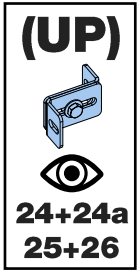
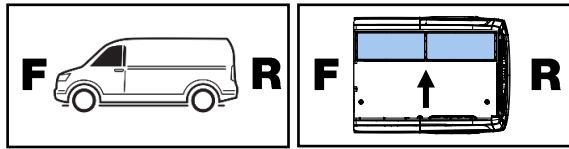

8b.

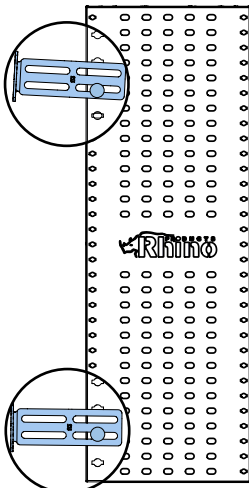
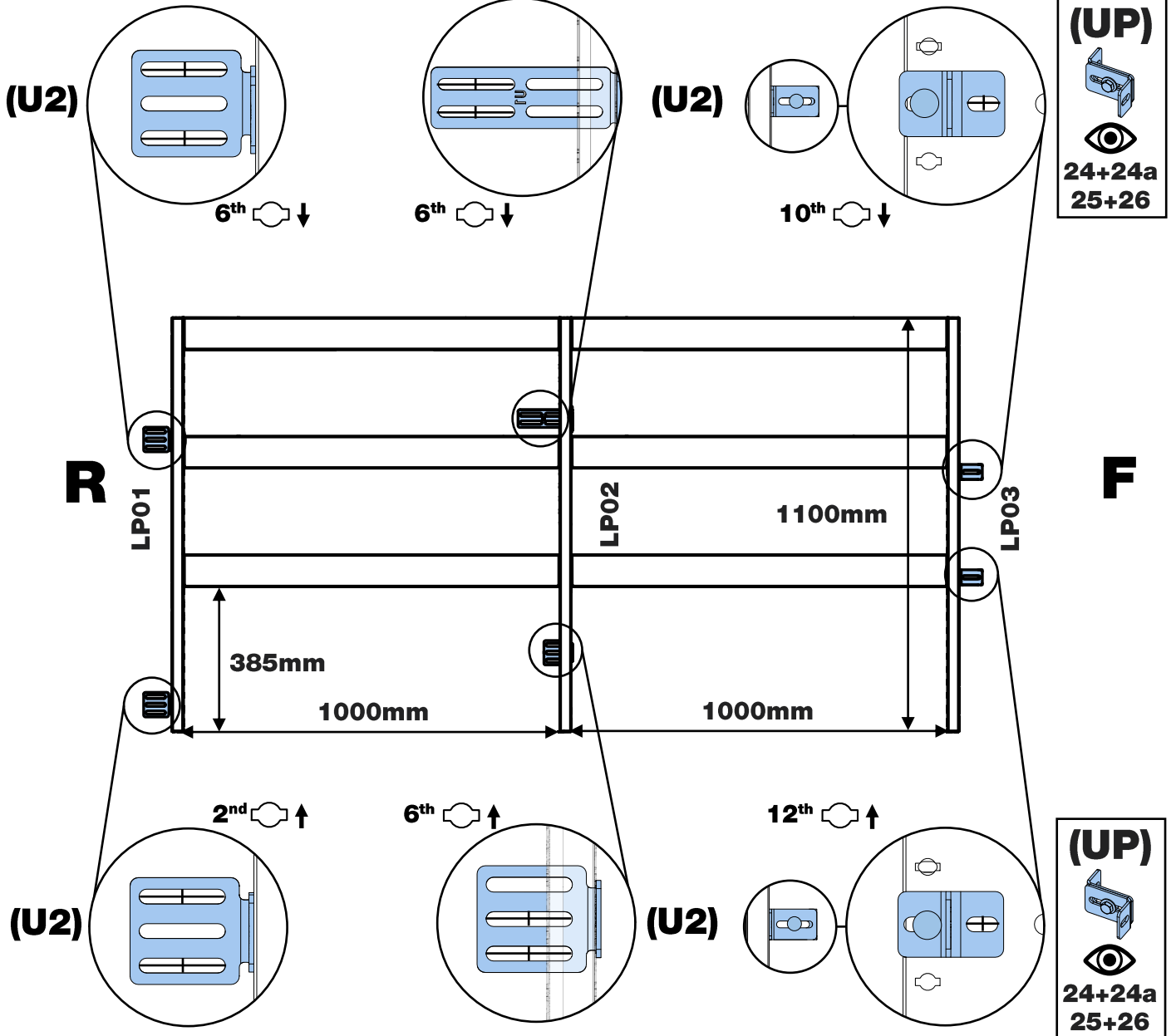

LP01

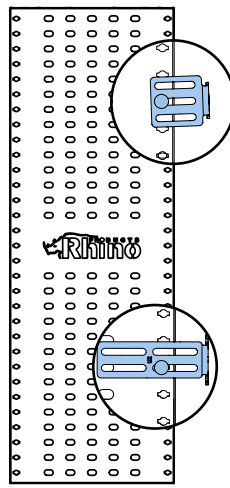

LP02

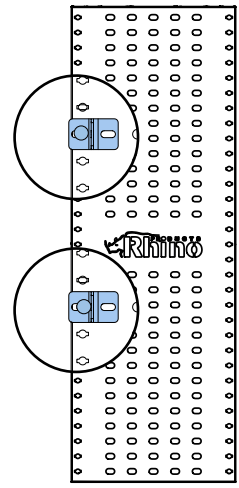

LP03

9.



10.

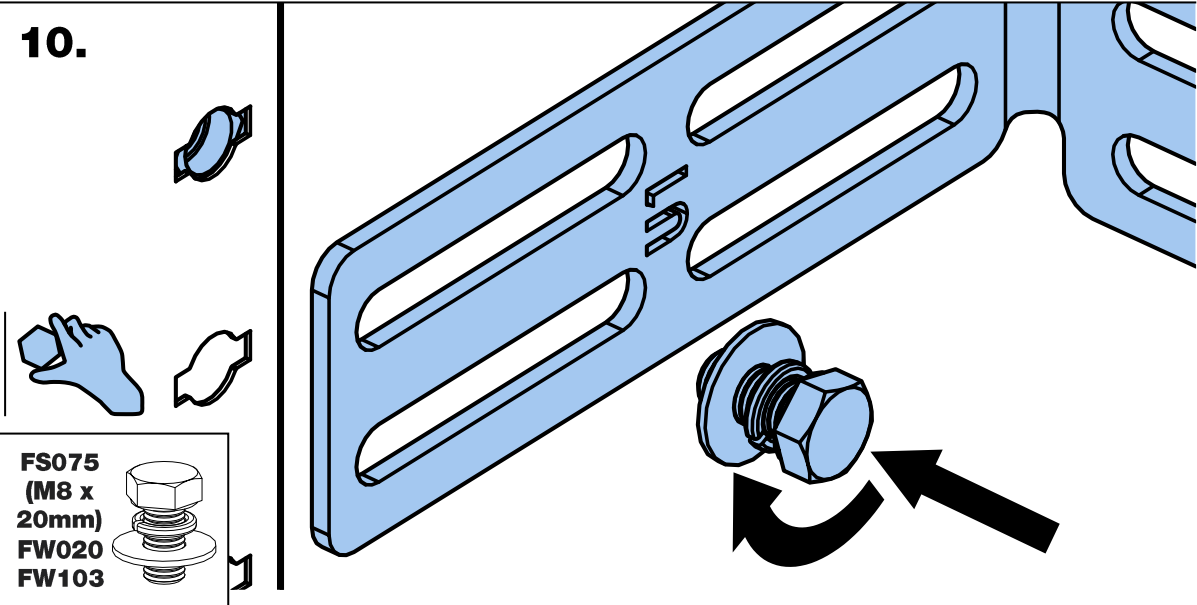

11.

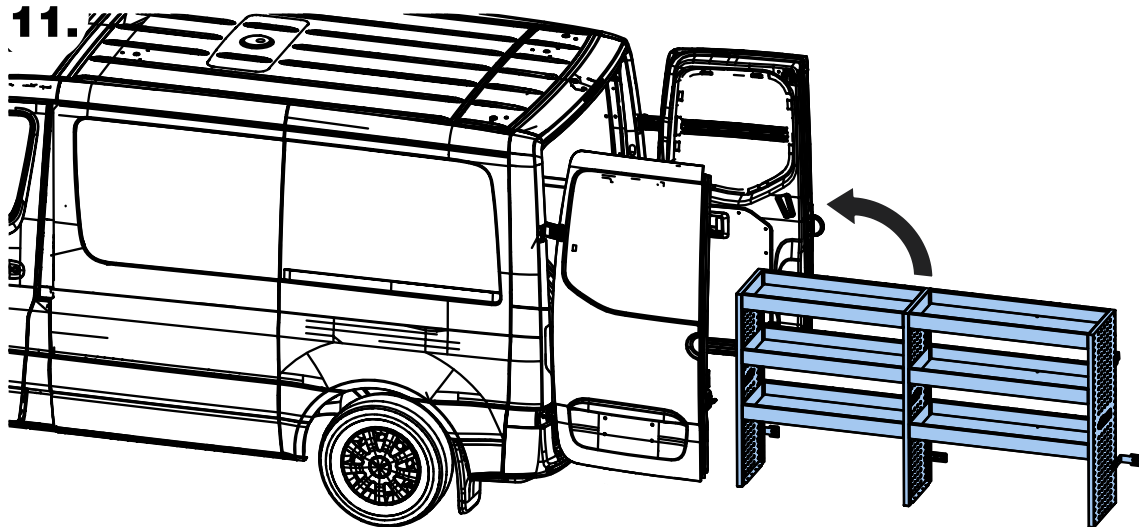



12a.

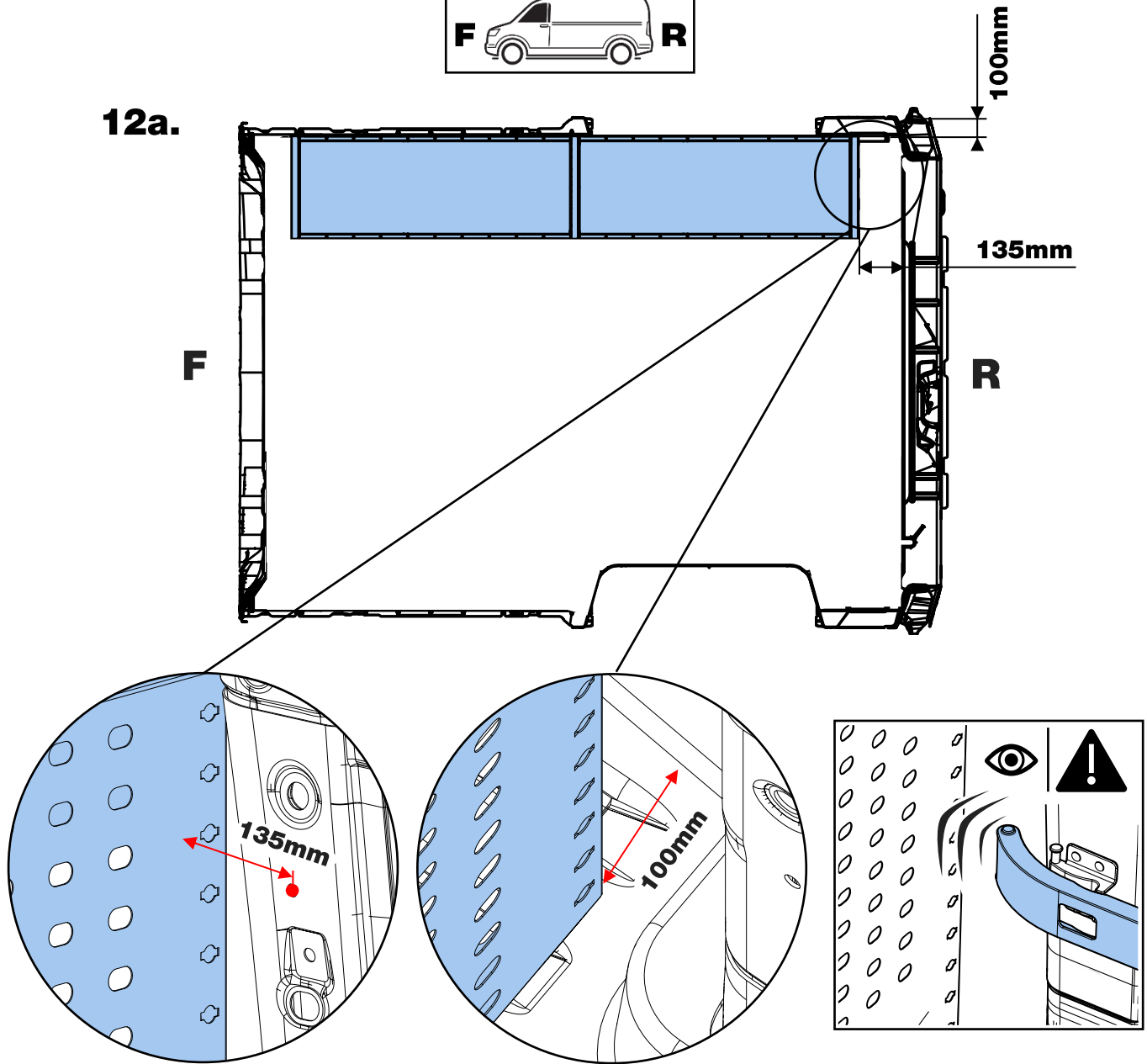

13a.

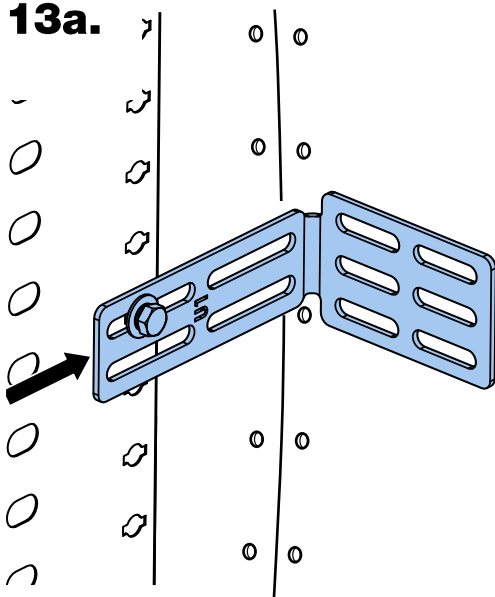

14a.

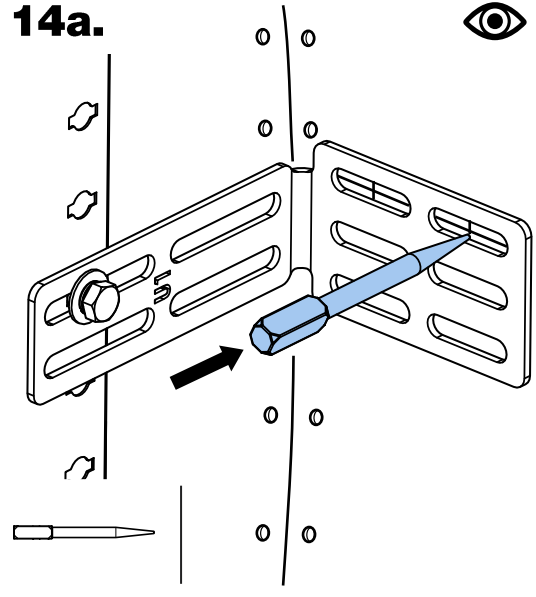



12b.

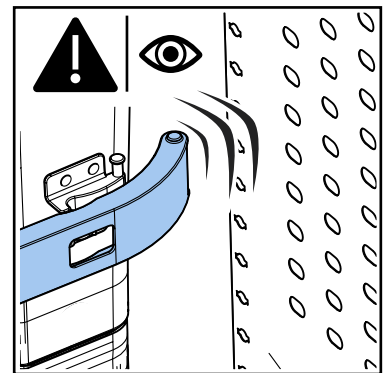
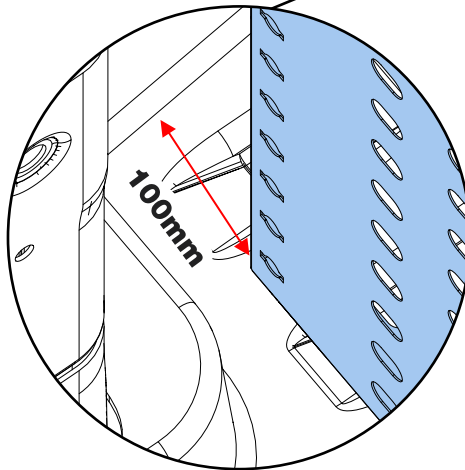
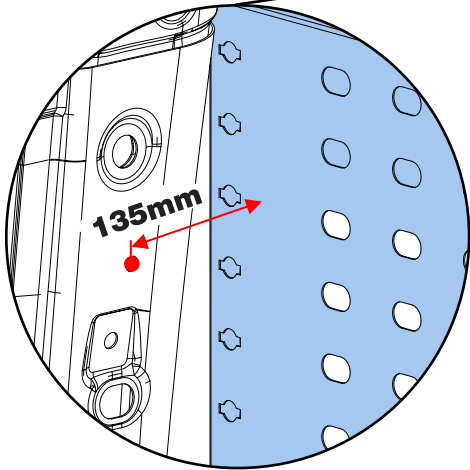
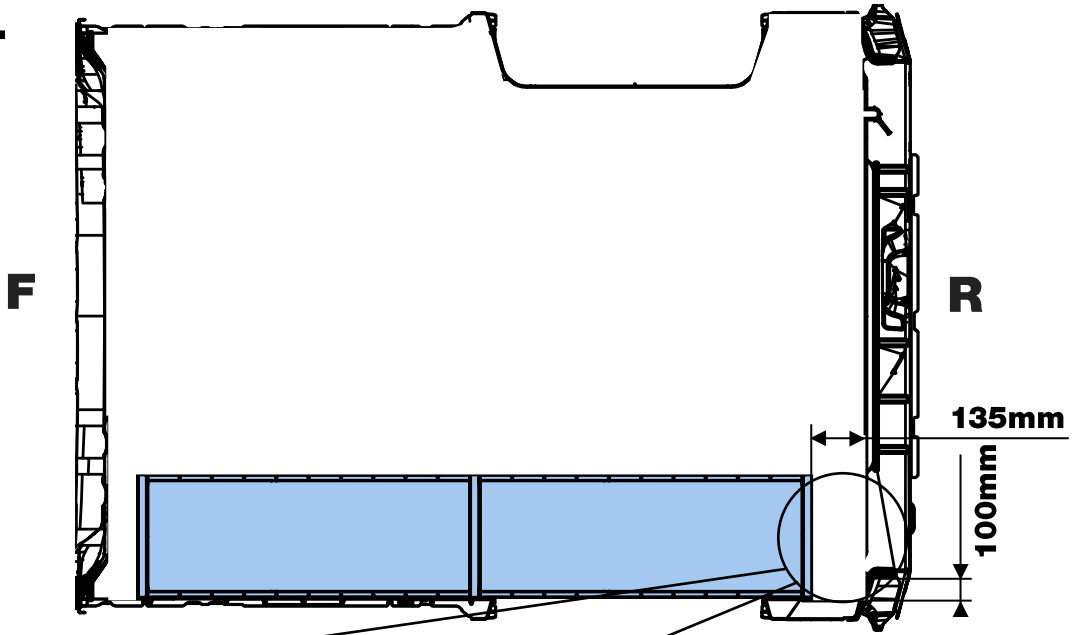

13b.

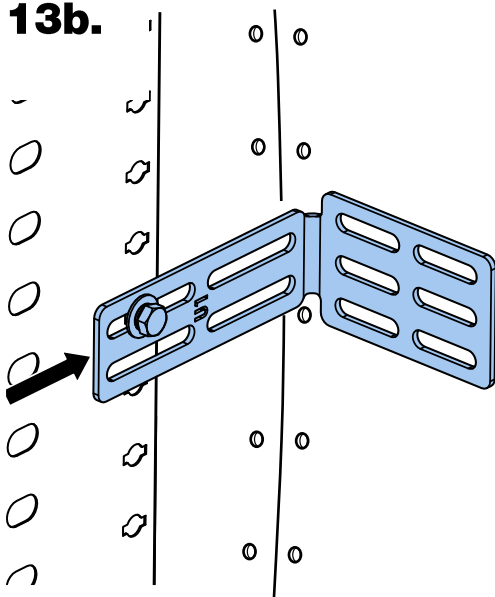

14b.

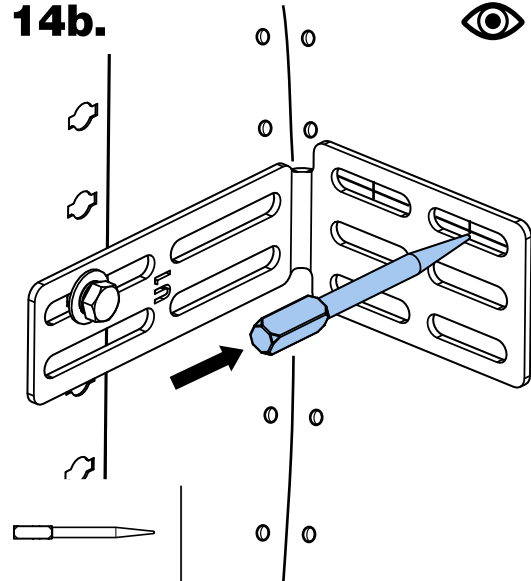

8b

15.



16.



17.



18.

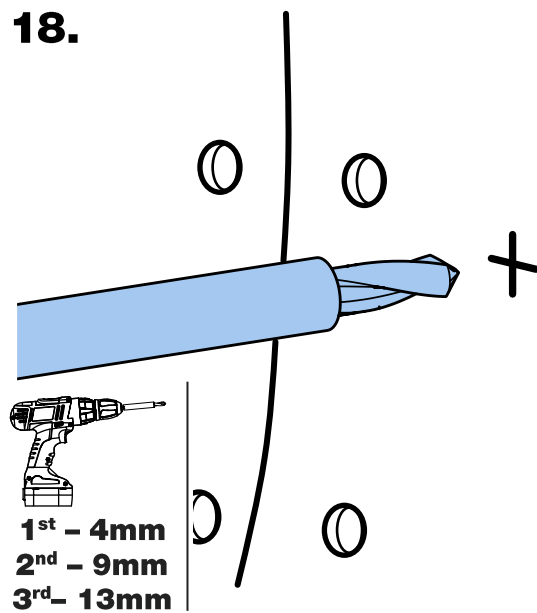

1st - 4mm
2nd - 9mm
3rd - 13mm

19.



20a.

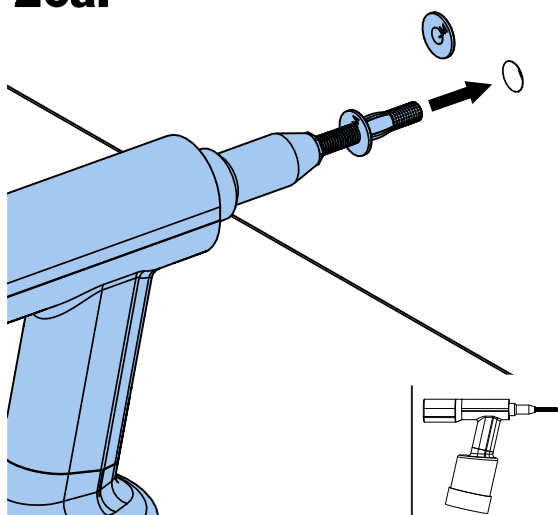

	Option 1: Use Rivet Gun & MB XL Mandrel.
	Option 1: Benutzen Sie eine Nietpistole & einen MB XL Zugdorn.
	Option 1 : Utiliser un pistolet à riveter et un mandrin MB XL.
	Opzione 1: utilizzare una pistola per rivetti e un mandrino MB XL.
	Opción 1: Use la remachadora y el cabezal MB XL.
	Opcja 1: należy użyć nitownicy z trzpieniem MB XL.
	Optie 1: Gebruik Klanknagelpistool & MB XL Opspandoorn.
	1. opció Használjon szegécseleő pisztolyt és MB XL tuskét.
	Alternativ 1: Använd en nitpistol och en MB XL borradapter.
	Varianta 1: Použijte nýtovací kladivo a trn MB XL.
	Vaihtoehto 1: Käytä niittivasaraa ja MB XL -tuurnaa.
	Alternativ 1: Bruk naglepistol og MB XL-mandring.
	Možnosť 1: Použite nitovacia pistol a trn MB XL.

20b.

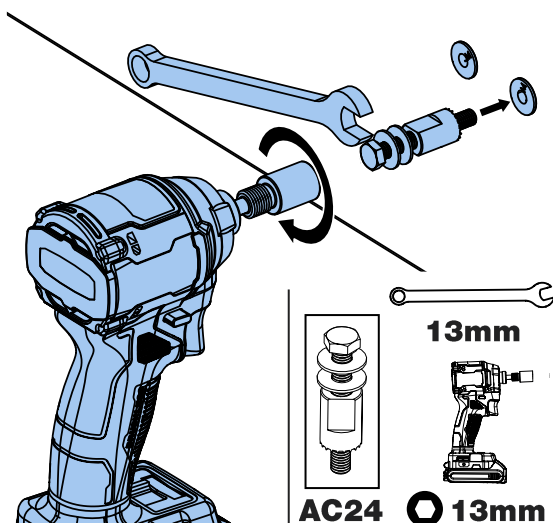

	Option 2: Use Impact Driver. AC24 Sold separately.
	Option 2: Benutzen Sie einen Schlagschrauber. Der AC24 wird separat verkauft.
	Option 2 : Utiliser une clé à choc. AC24 vendue séparément.
	Opzione 2: utilizzare l'avvitatore a percussione AC24 venduto separatamente.
	Opción 2: Use el atornillador de impacto. La herramienta AC24 se vende aparte.
	Opcja 2: należy użyć wkrętarci udarowej; klucz AC24 dostępny jest do nabycia osobno.
	Optie 2: Gebruik Slagschroevendraaier. AC24 wordt apart verkocht.
	2. opció Használjon ütvefűrórt. Az AC24 külön vásárolható meg.
	Alternativ 2: Använd en slagbormaskin. AC24 säljs separat.
	Varianta 2: Použijte příklepový utahováč. AC24 se prodává samostatně.
	Vaihtoehto 2: Käytä iskuväännintä. AC24 myydään erikseen.
	Alternativ 2: Bruk slagskrutrekker. AC24 selges separat.
	Možnosť 2: Použite elektrický utahováč. AC24 Predáva sa samostatne.

20c.

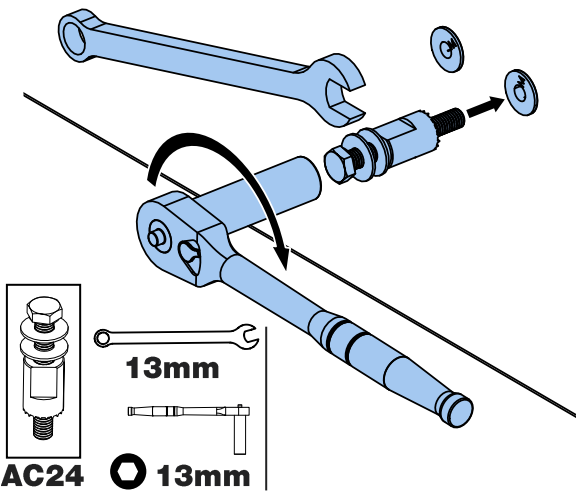

	Option 3: Use Socket Wrench AC24 sold separately.
	Option 3: Benutzen Sie den separat verkauften AC24 Steckschlüssel.
	Option 3 : Utiliser la clé à douille AC24 vendue séparément.
	Opzione 3: utilizzare la chiave a bussola AC24 venduta separatamente.
	Opción 1: Use la remachadora y el cabezal M8 XL.
	Opція 3: należy użyć klucza nasadowego AC24 dostępnego do nabycia osobno.
	Optie 3: Gebruik de apart verkochte Dopsleutel AC24.
	3. opció Használjon csavarkulcsot. Az AC24 külön vásárolható meg.
	Alternativ 3: Använd hylsnyckel. AC24 säljs separat.
	Varianta 3: Použijte nástrčný kľúč AC24, ktorý sa predáva zvlášť.
	Vaihtoehto 3: Käytä hylsyavainta AC24, joka myydään erikseen.
	Alternativ 3: Bruk pipenøkkel AC24 som selges separat.
	Možnosť 3: Použite nástrčný kľúč AC24, ktorý sa predáva samostatne.

21.



22.

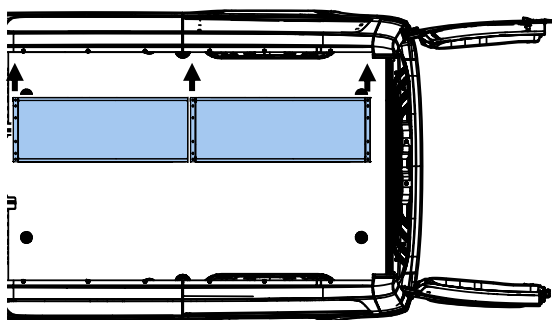

23.

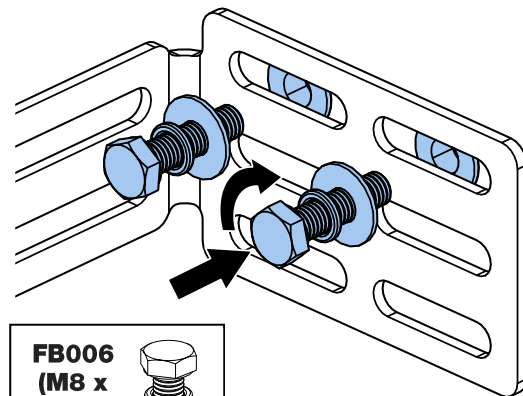

FB006
(M8 x
30mm)
FW020
FW103

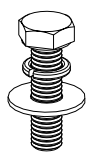

24.

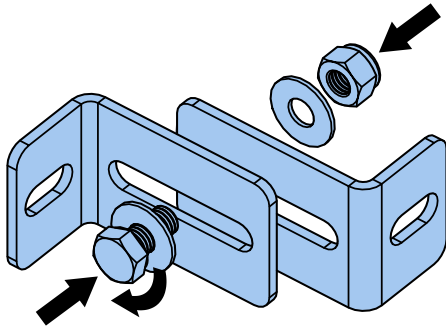

FS075
(M8 x
20mm)
FW103 x2
FN041

24a.

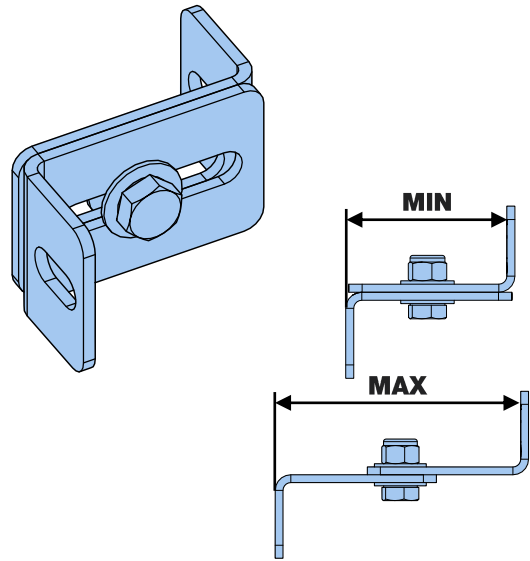

24b.

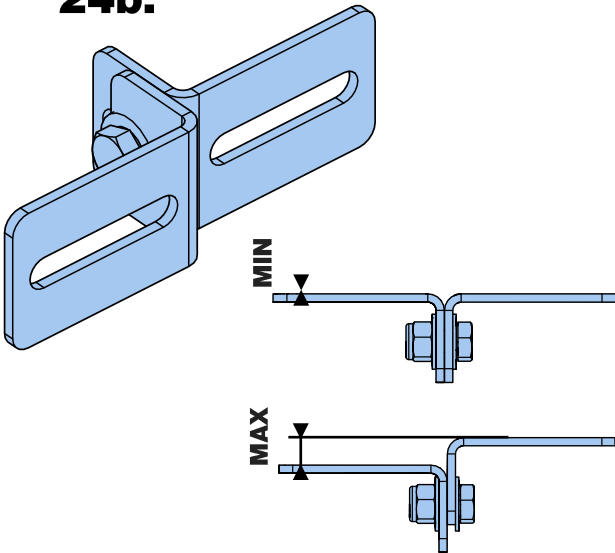

24c.

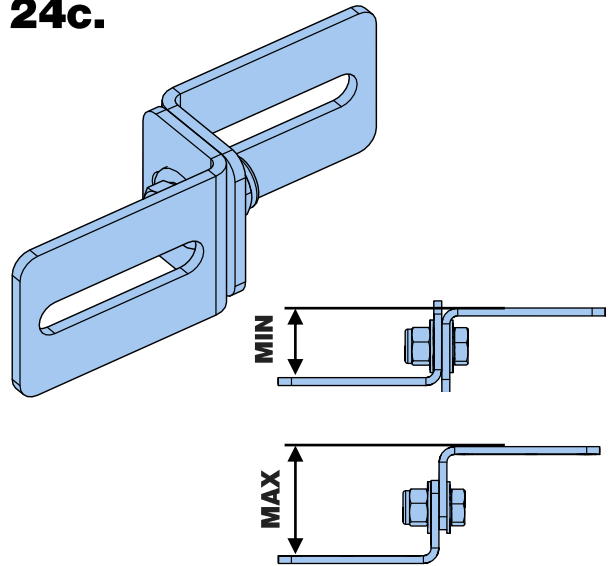

25.

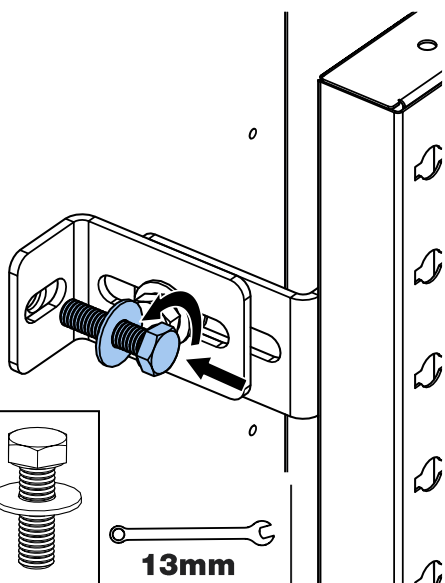

FB006
(M8 x
30mm)
FW103

13mm

26.

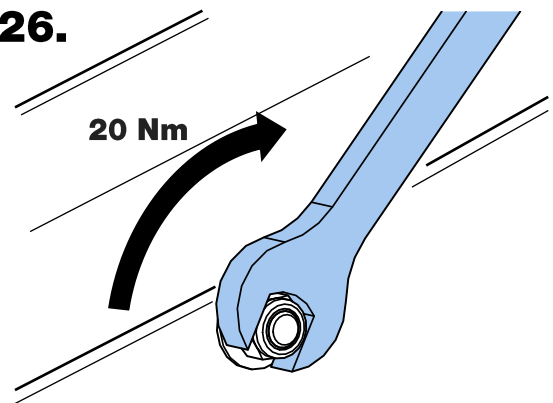

13mm

FN041
(M8)
FW103

27.

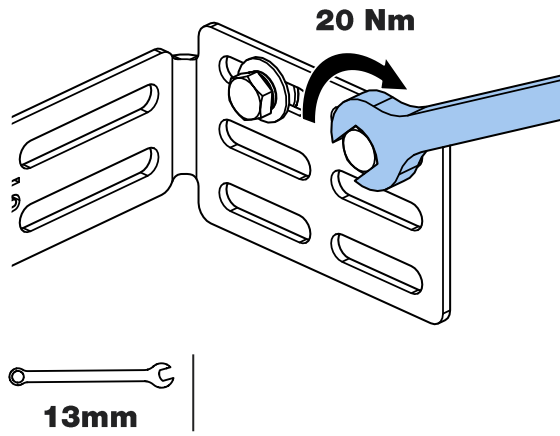

28.

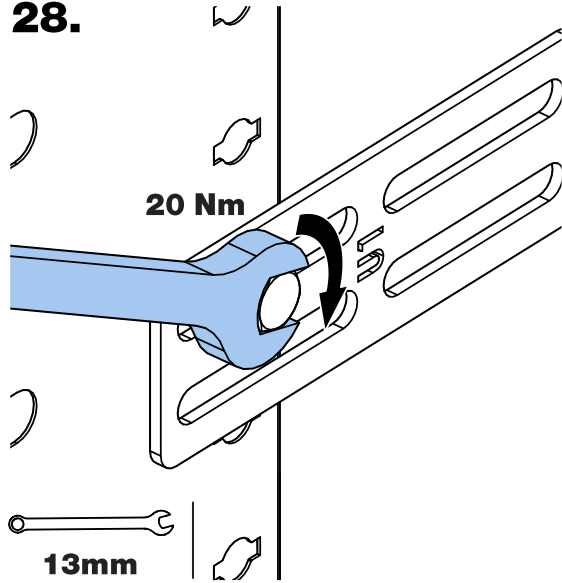

29.

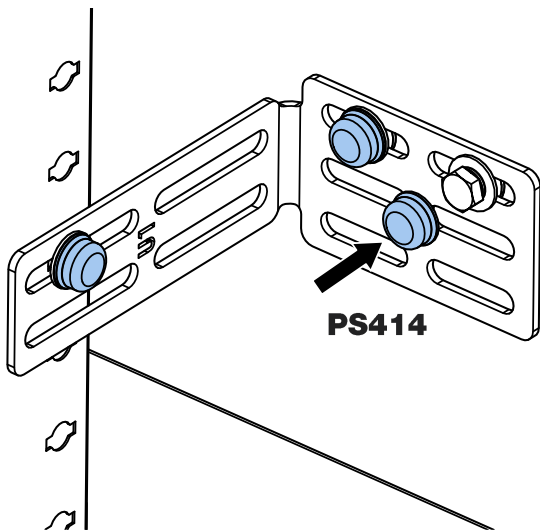

30.

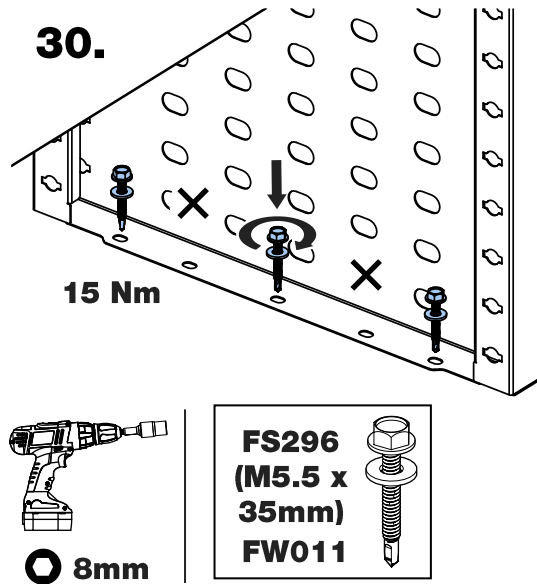

31.

