

ISSUE:	DRAWN BY:	CHECKED BY:	CRF No:	DATE:	DESCRIPTION:
a	LE	KB	2699	05/05/22	First Issue
b	LE	KB	2786	18/08/22	Removed TUV label + amended eye icon information (P.3)
c	SJ	KB	3243	04/06/24	Added FS310 x 2
d	SJ	KB	3418	06/02/25	Added Custom 2024-
e					
f					
g					
h					
i					
j					
k					
l					
m					

TS11BR TowStep

Instructions

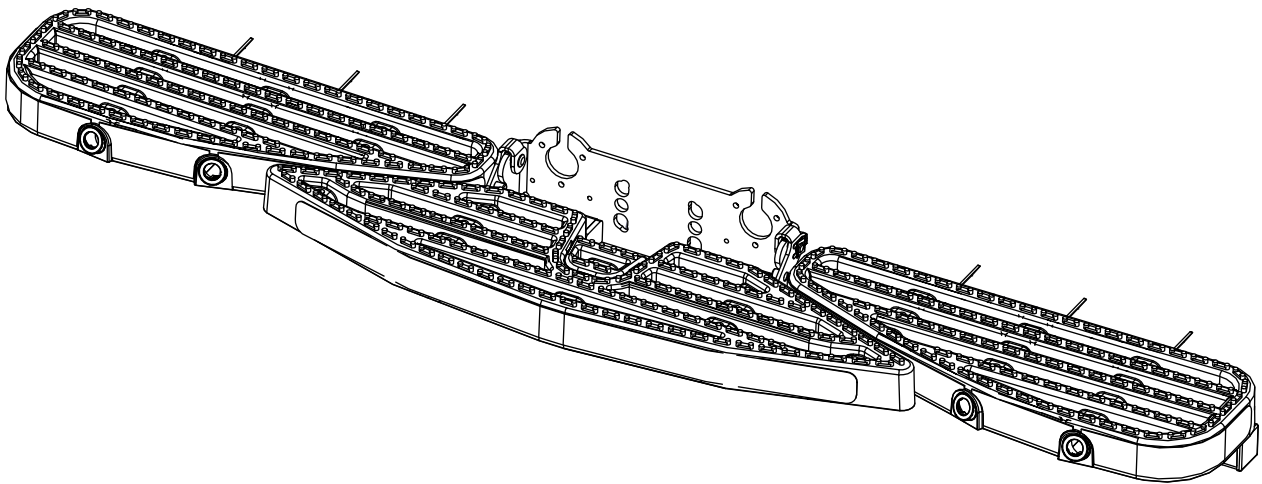

TS11BRFI:

CITROEN Dispatch 2019-, Relay/Jumper 2006-
FIAT Ducato 2006-
FORD Transit 2014-, Custom 2012-2018, 2024-
IVECO Daily 2014-
MAN TGE 2017-
MAXUS Deliver9 2020-
MERCEDES Sprinter 2018-
PEUGEOT Boxer 2006-, Expert 2019-
RENAULT Master 2010-, Trafic 2014-
TOYOTA Proace 2019-
VAUXHALL/OPEL Movano 2010-, Vivaro 2014-
VW Crafter 2017-, T5/T6 2015-

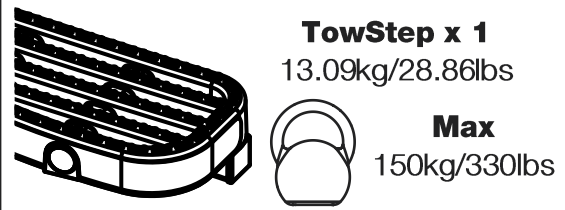

Max
 150kg/330lbs

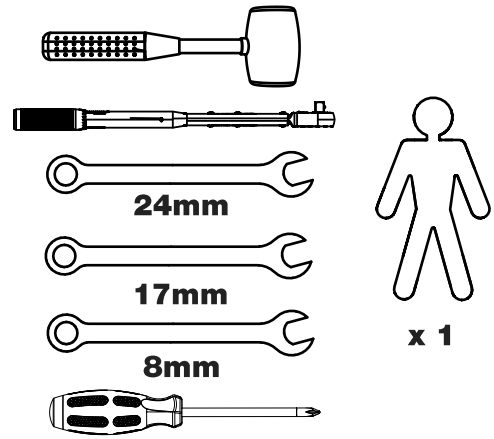

TowStep

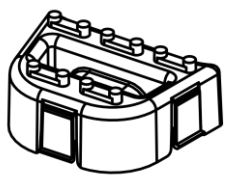

PS507 x 1

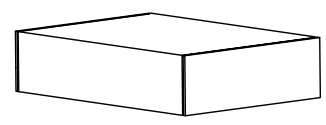

RSA001 x 1

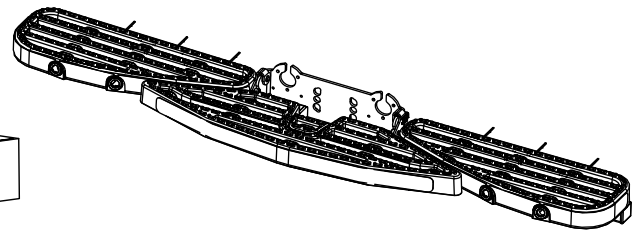



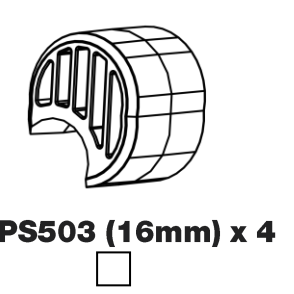
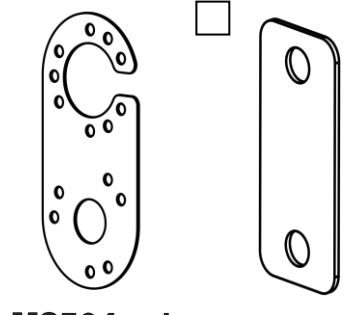
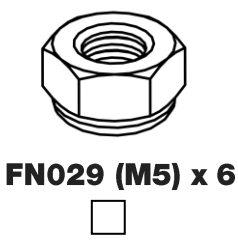
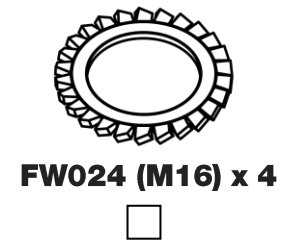
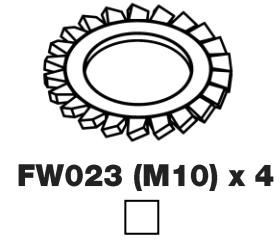
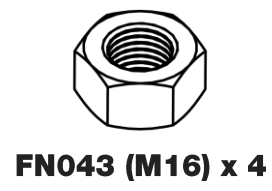
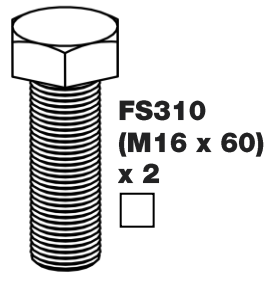
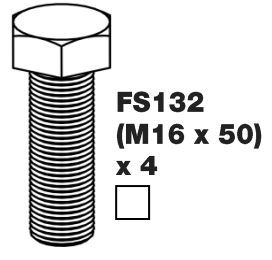
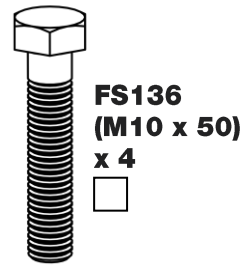
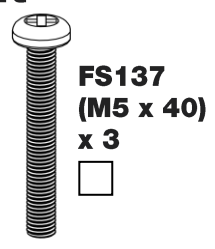
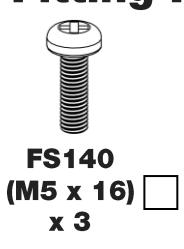

TS11BR x 1

Fitting Kit

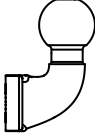
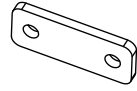
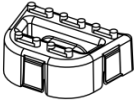
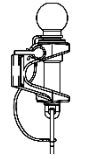
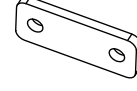

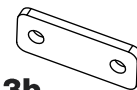

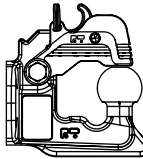
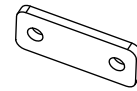
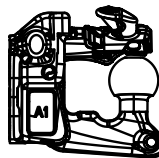
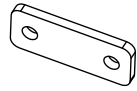
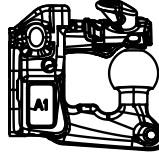
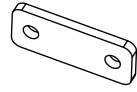
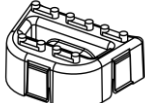
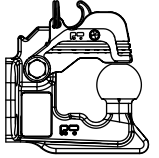
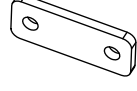
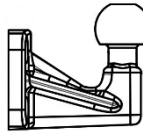
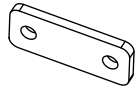
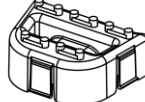
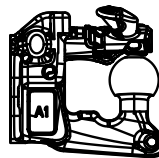
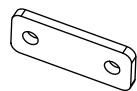
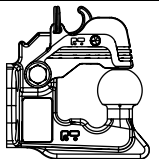
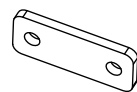
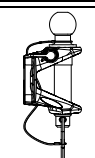
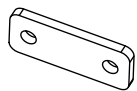
M16 x 2	Standard 50mm Tow Ball		MS1150 ✗ 	
	Bradley Ball & Pin (185080815)		MS1150 ✗ 	PS507 ✓
	Dixon Bate (185002015)		MS1150 ✓  3b.	
	Crochet à boule 70C (2905019)		MS1150 ✗ 	PS507 ✗
	MULTIS - Crochet à boule mixte (2905080)		MS1150 ✗ 	✗
M16 x 4	MULTIS - Crochet à boule mixte (2905083)		MS1150 ✗ 	
	Crochet à boule 70C (2905024)		MS1150 ✗ 	PS507 ✗
M10 x 4	Universal 4 Hole Flange		MS1150 ✗ 	
	MULTIS - Crochet à boule mixte (2905081)		MS1150 ✗ 	PS507 ✗
	Crochet à boule 70C (2905022)		MS1150 ✗ 	✗
	Euro 4 Bolt & Pin (185075015)		MS1150 ✗ 	PS507 ✓



A. M10 x 4

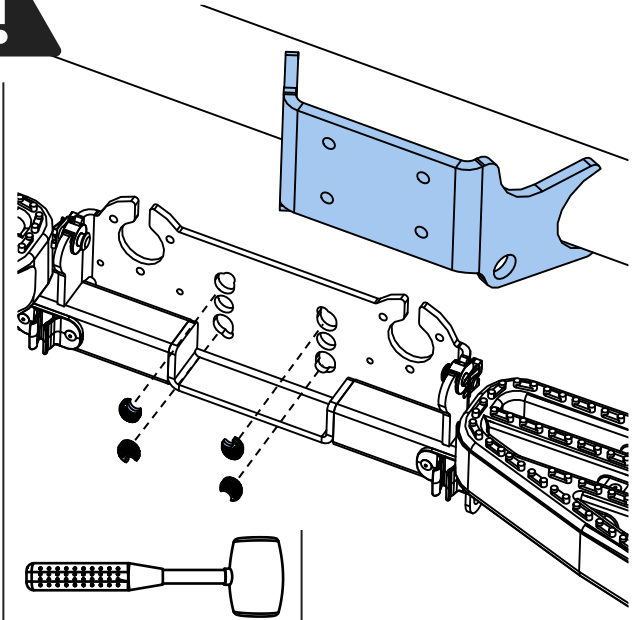
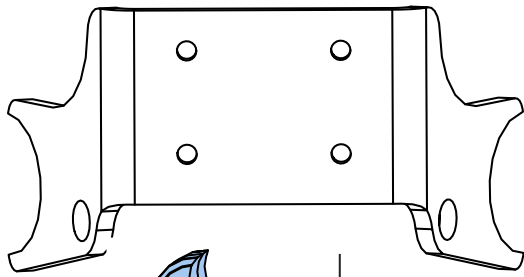

B. WITTER

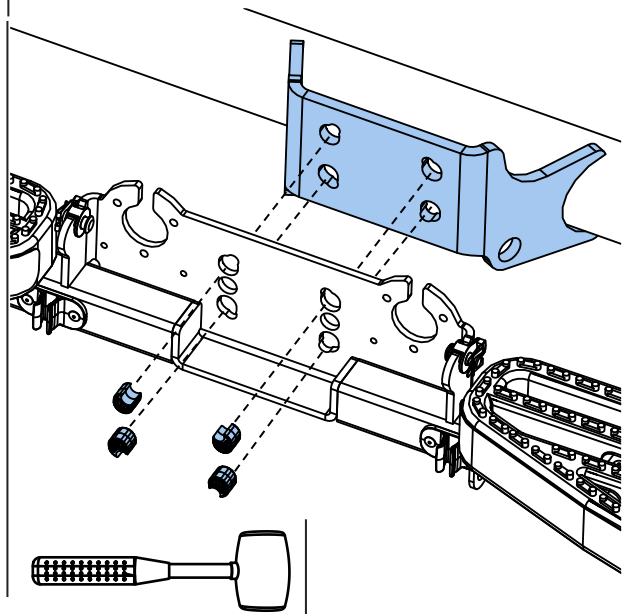
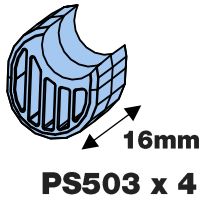
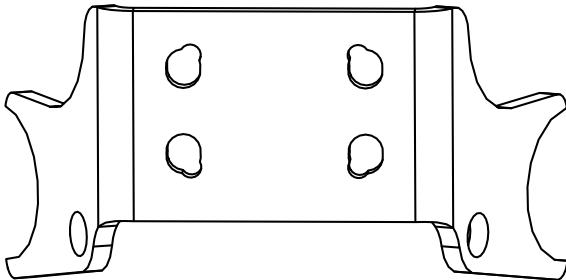

C. M16 x 4

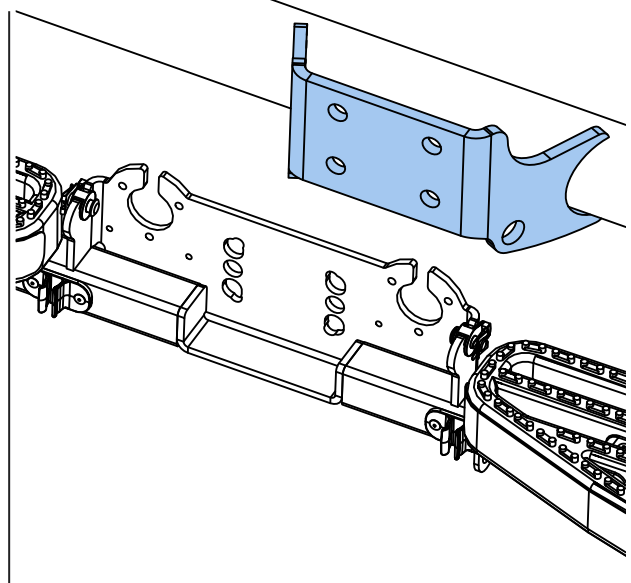
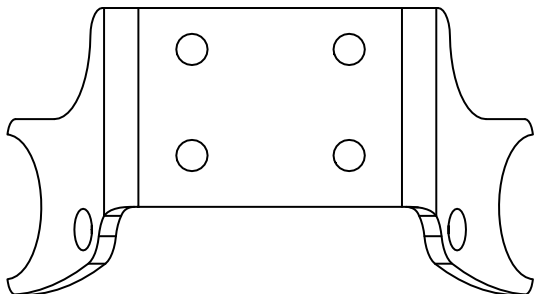

1.

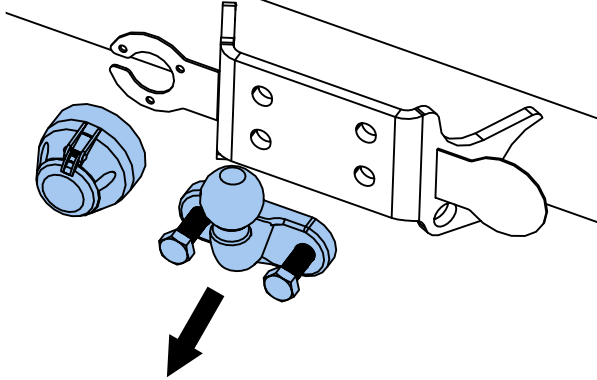

2.

M16 x 50/60 M10 x 50

FS132/
FS310

FW024

FN043

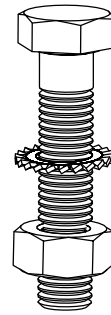
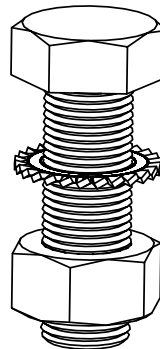

FS136

FW023

FN045

3a.

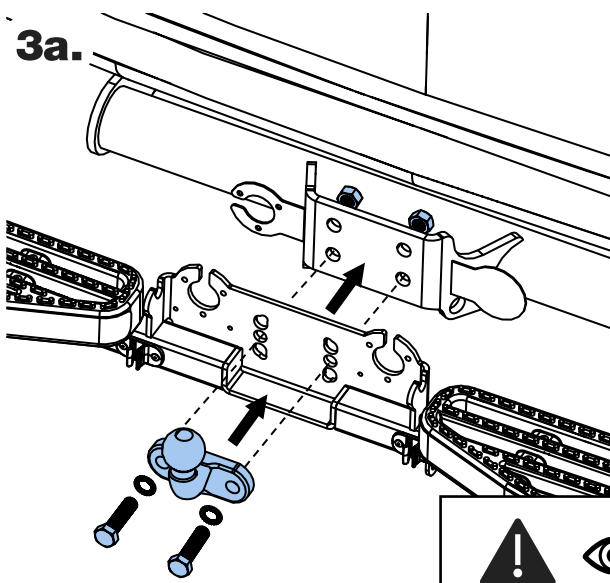

3b.

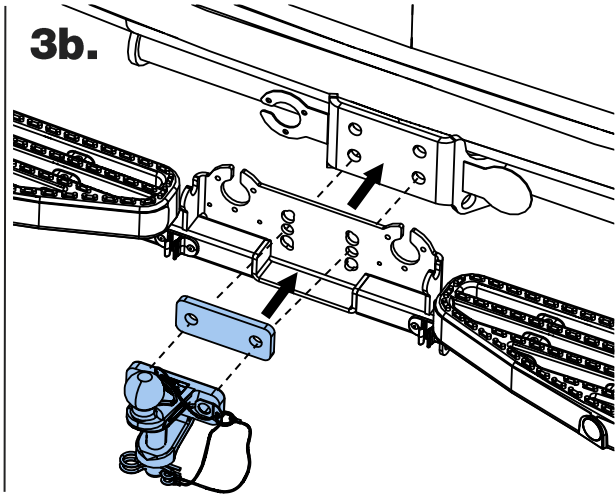

P.3

(Dixon Bate Only)

4.

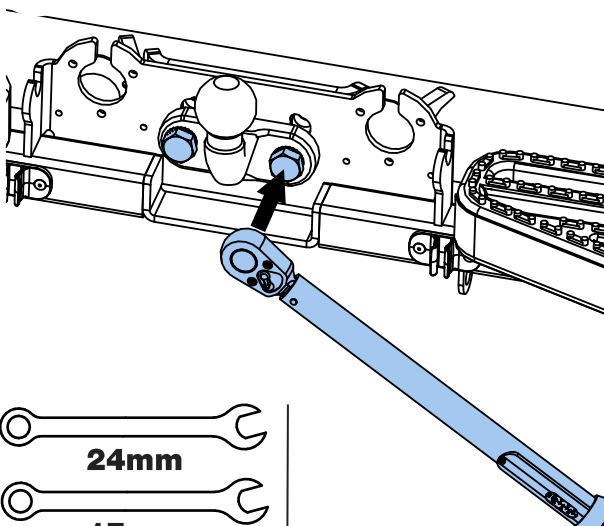

24mm

17mm

5.

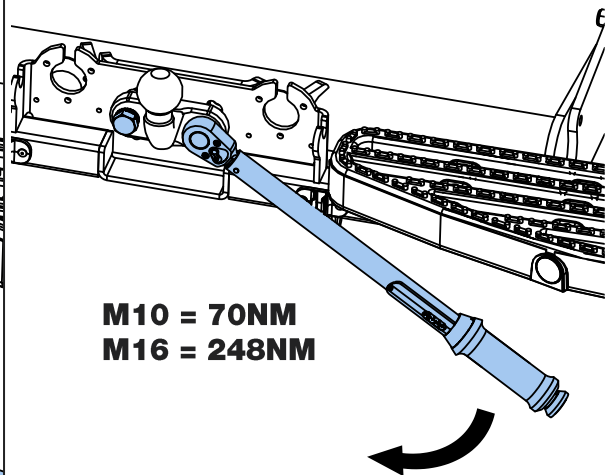

M10 = 70NM
M16 = 248NM

6.

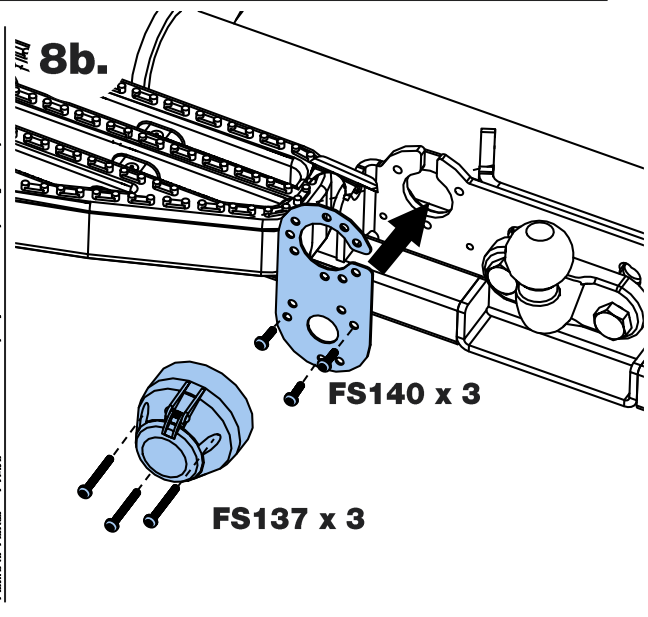
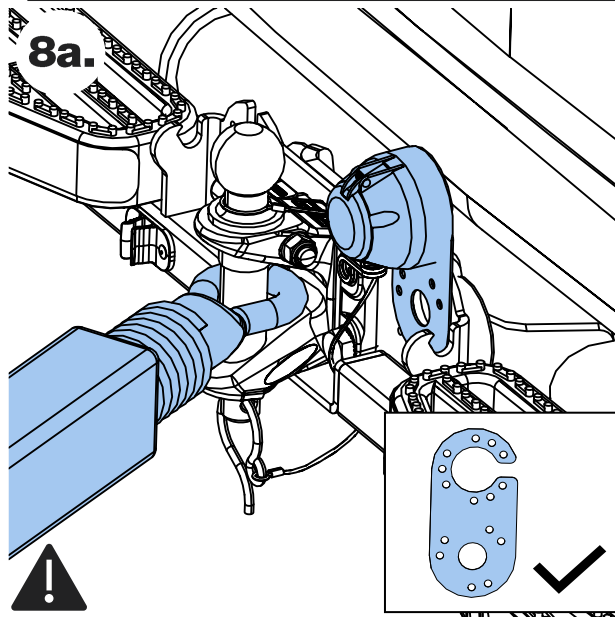
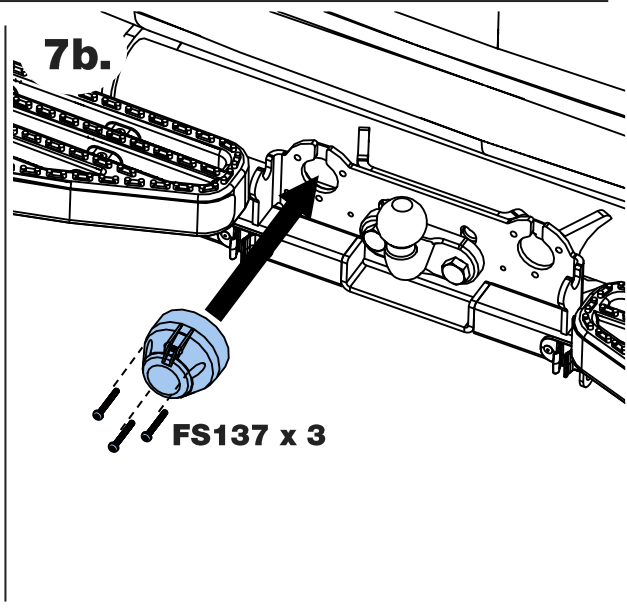
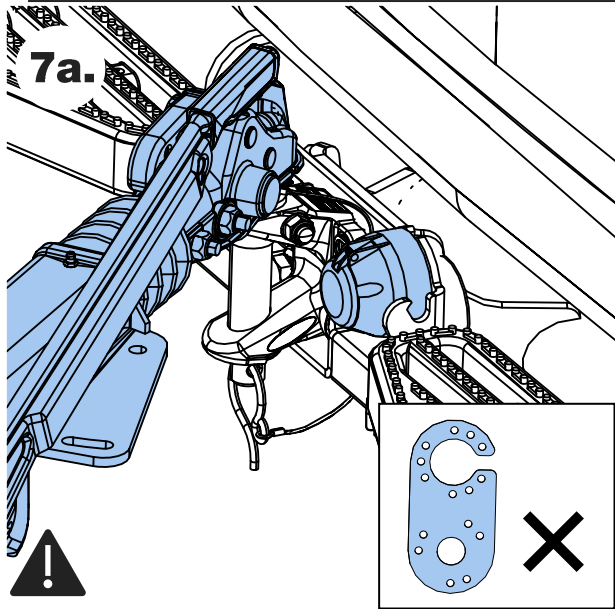
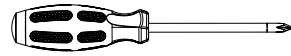
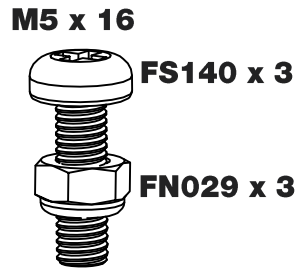
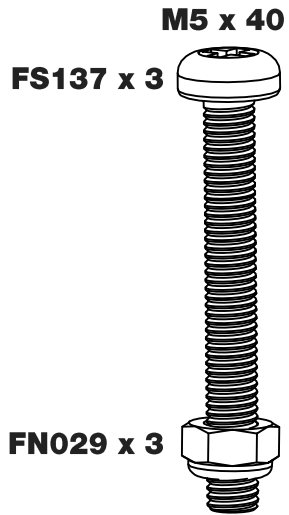

9.

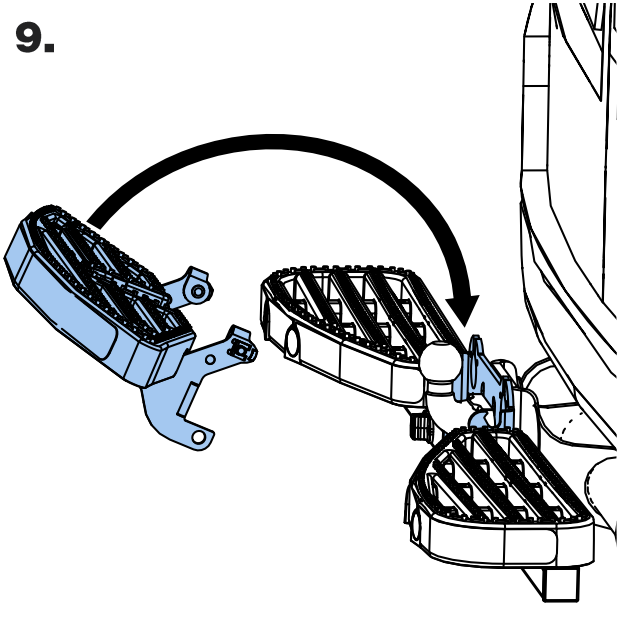

10.

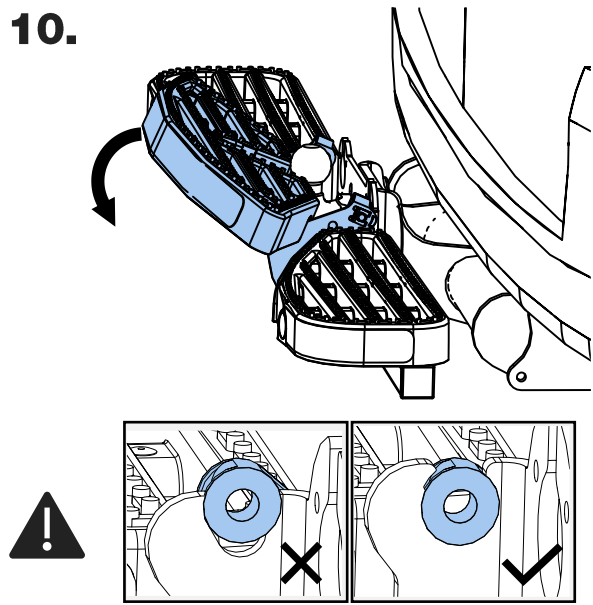

11.

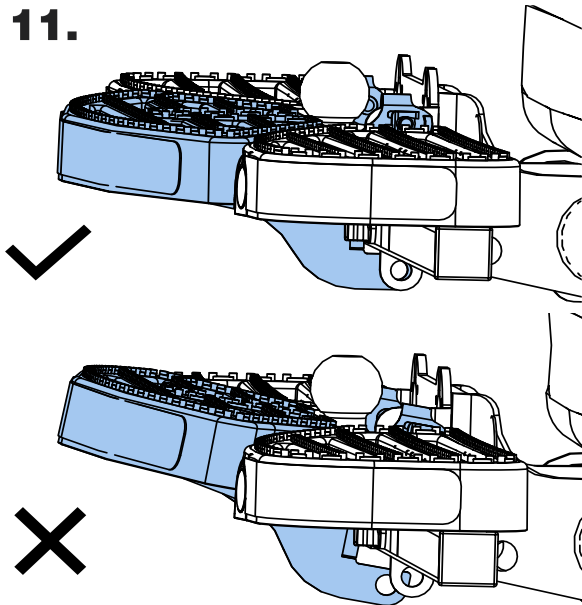

12.

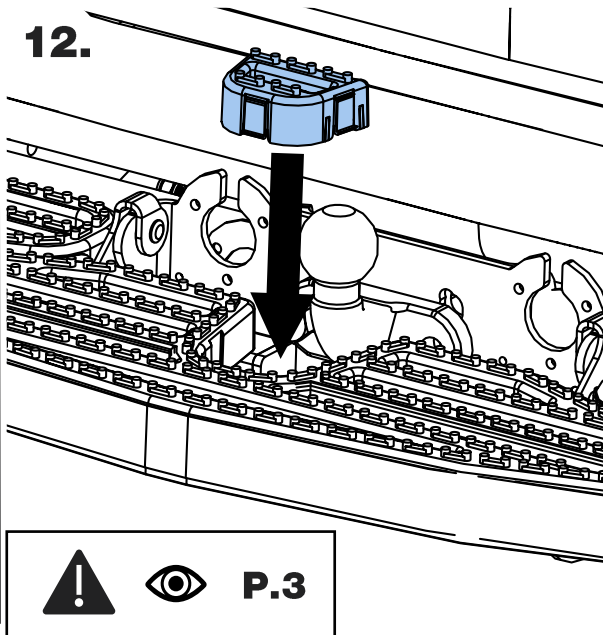

13.

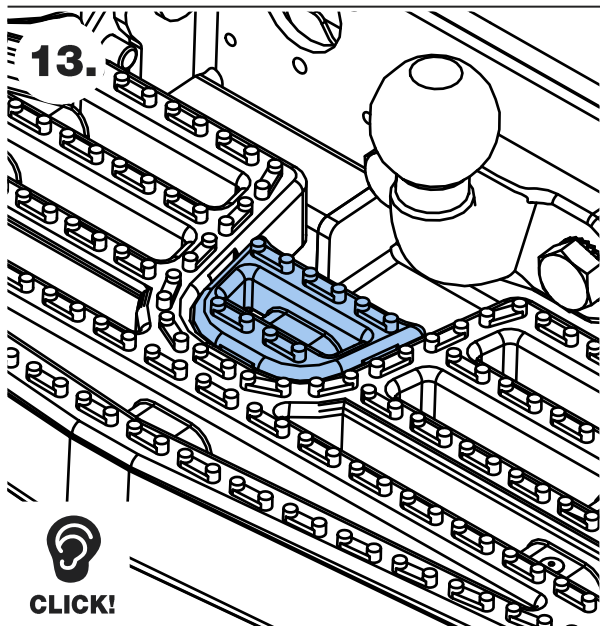

14.

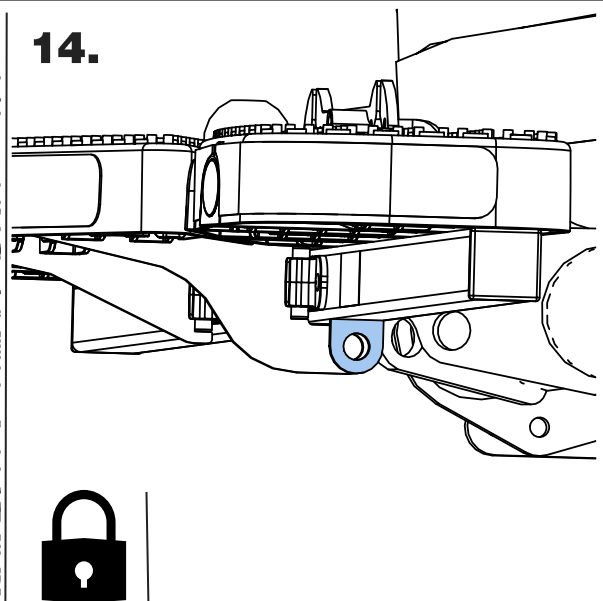

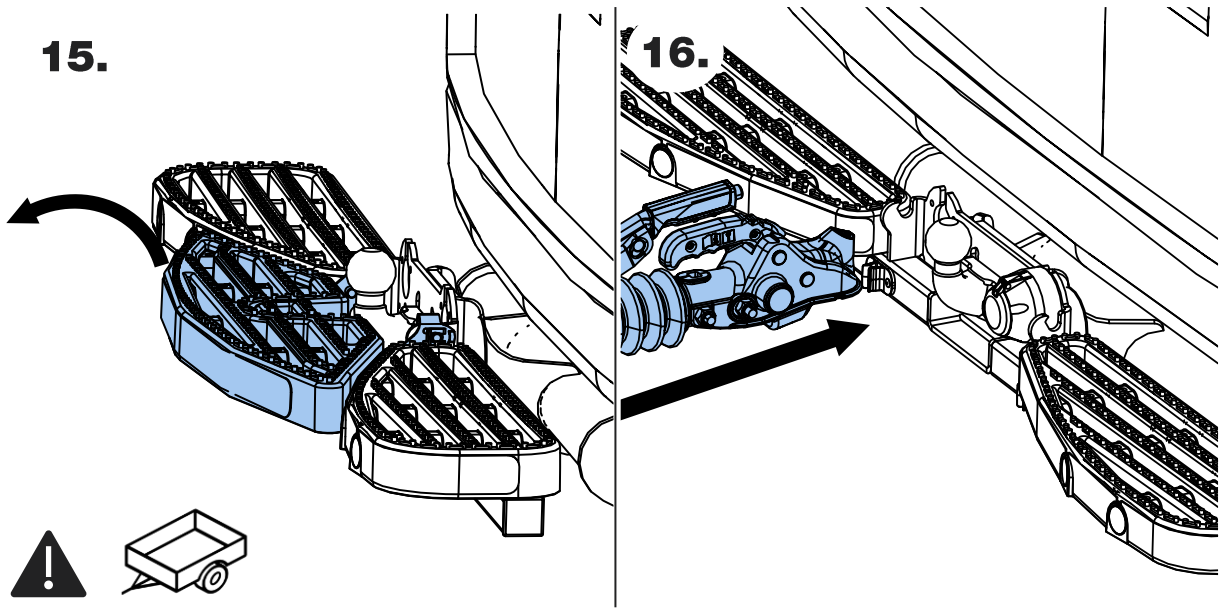

17.

RSA001

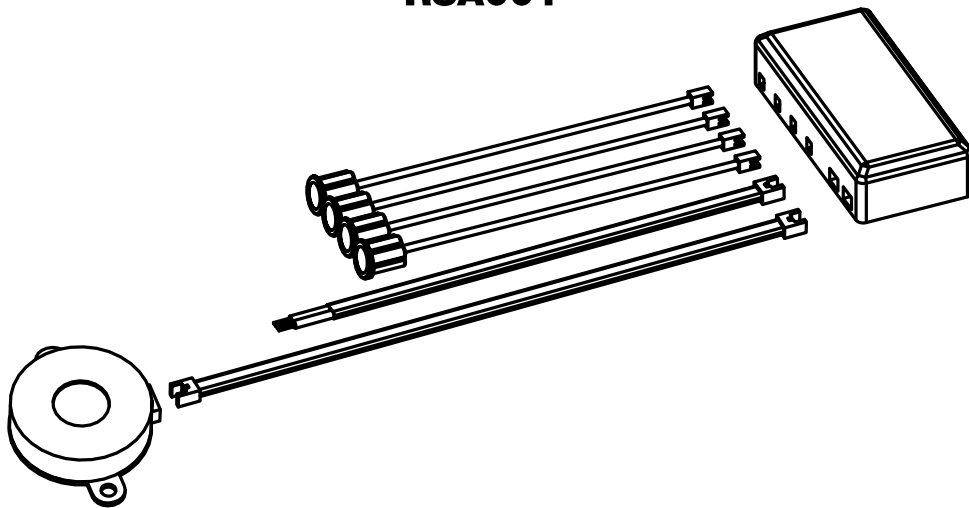

18a.

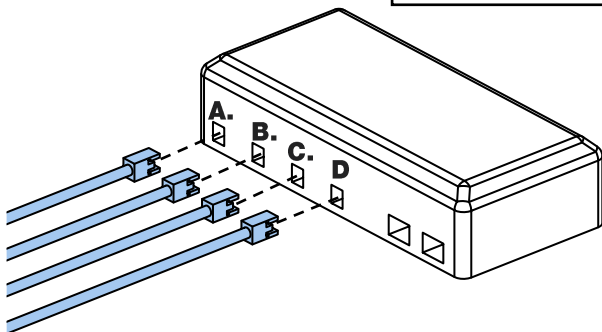
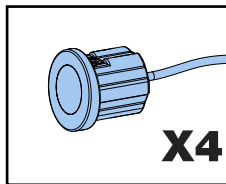

18b.

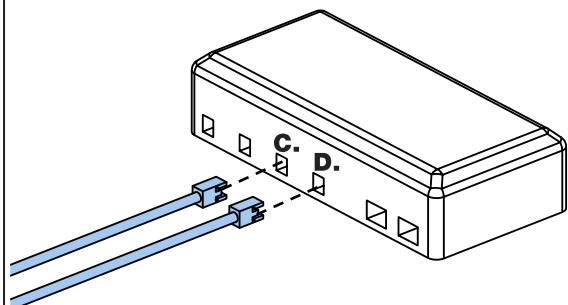
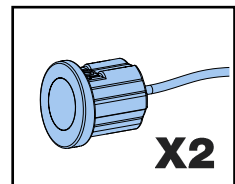

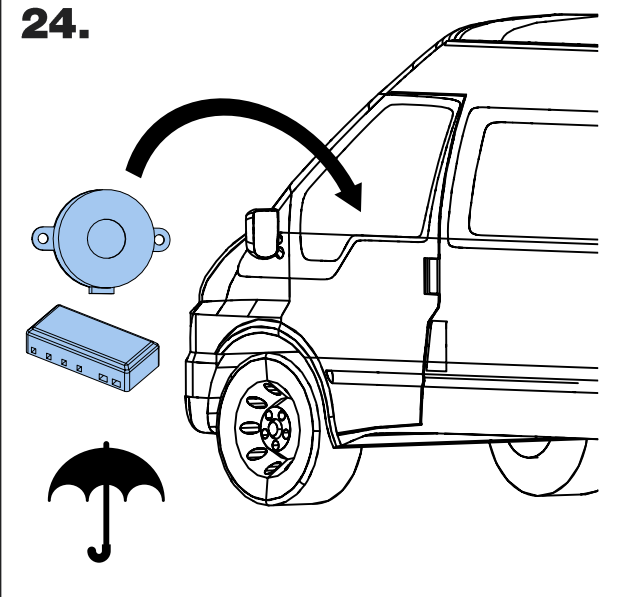
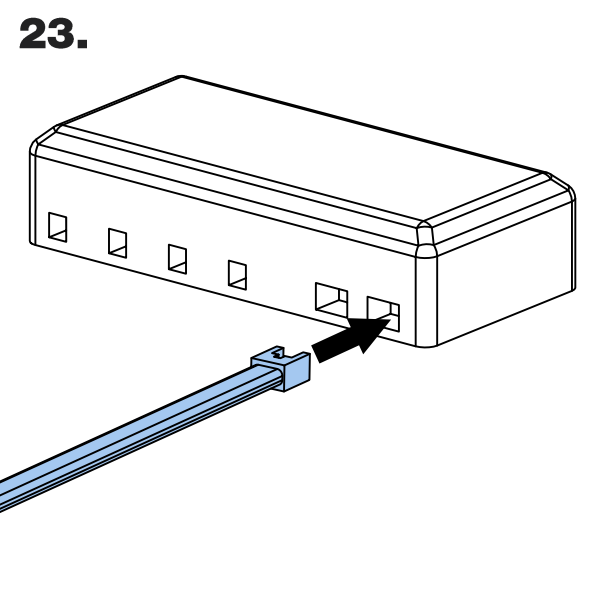
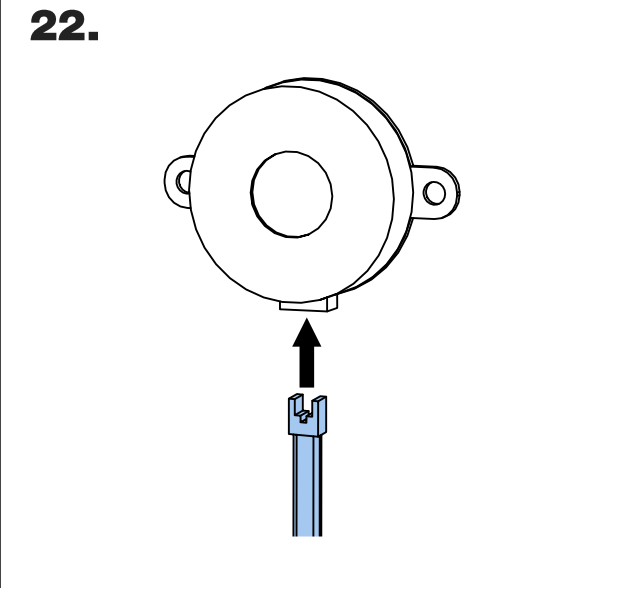
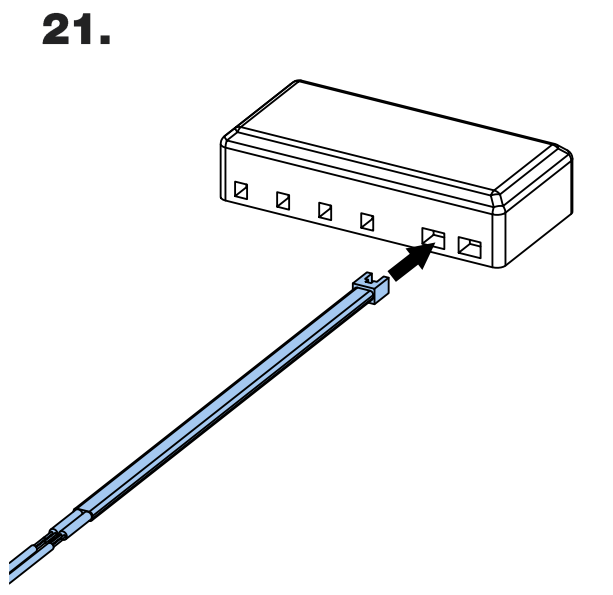
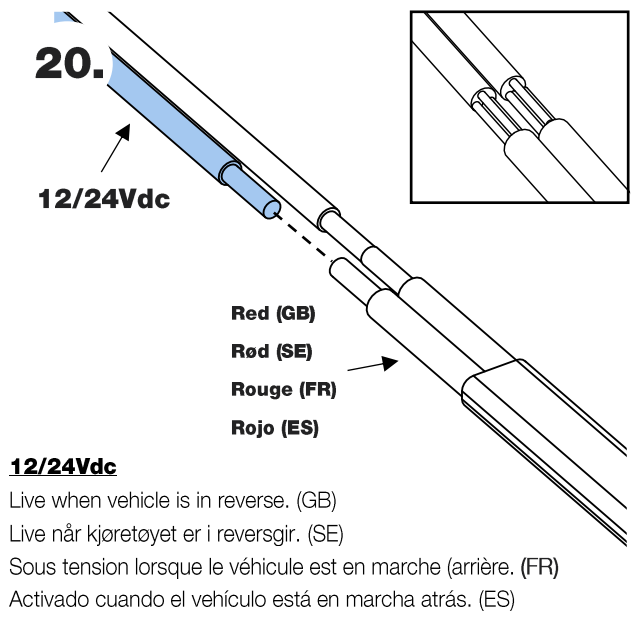
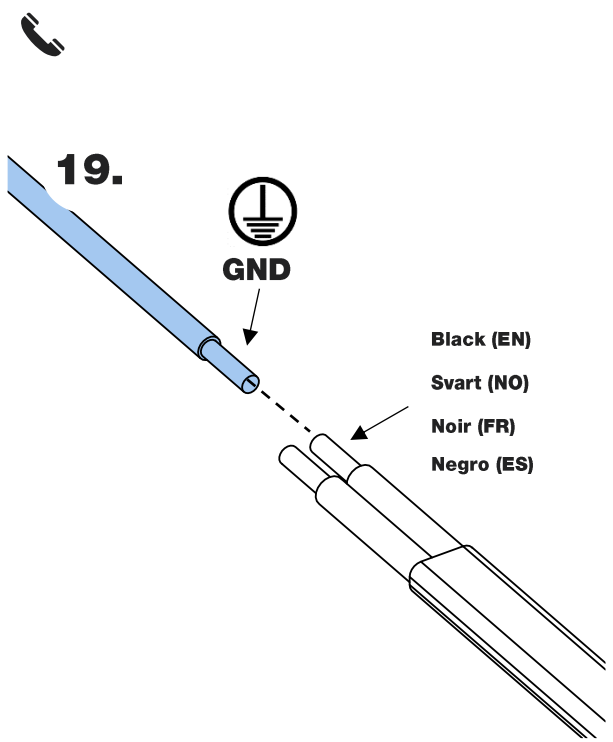

**Technical information (GB)****Key Features**

- 4 Sensor Audible Kit
- Towbar Intelligent (Dip switch 1 rear of ECU control unit)
- Sensor height adjustable 45cm-55cm
- Self-Test function
- 21mm Sensors
- 4&2 sensor option
- 2 eye – use C & D on the ECU control unit
- Buzzer size: 42 x 16mm

Technical Specifications

- Operating voltage range: 12/24 volt
- Ultrasonic frequency: 40KHz
- Control Working temperature: -30 - +70 °C
- Detection Range: 0.2 – 1.5m
- Rated Current: 20-200mA

Switch 1: The system will not alarm if there is a towbar and spare tyre in the back side of the vehicle.

Switch 2: Distance control function shortens the detection distance of sensor A&D to 1M which is 20cm shorter than the original distance. The buzzer alarms the rear distance between obstacles and Towbar / spare tyre, instead of distance between obstacle and bumper.

Teknisk informasjon (SE)**Viktige funksjoner**

- 4-sensors hørbart sett
- Tilhengerfeste, intelligent (dippbryter 1 bak ECU-kontrollenhet)
- Sensorhøyde justerbar 45 cm - 55 cm
- Selvtestfunksjon
- 21 mm sensorer
- 4&2 sensoralternativ
- 2 maljer – bruk C & D på ECU-kontrollenheten
- Alarmstørrelse: 42 x 16mm

Tekniske spesifikasjoner

- Driftsspenningsområde: 12/24 volt
- Ultrasonisk frekvens: 40KHz
- Kontroll driftstemperatur: -30 - +70 °C
- Deteksjonsområde: 0,2 – 1,5 m
- Nominell spenning: 20-200 mA

Bryter 1: Systemet vil ikke avgi alarm hvis det er et tilhengerfeste og reservedekk på baksiden av kjøretøyet.

Bryter 2: Avstandskontrollfunksjonen forkorter deteksjonsavstanden til sensor A&D til 1M, som er 20 cm kortere enn den opprinnelige avstanden. Alarmen varsler bakre avstand mellom hindringer og tilhengerfestet / reservedekket, i stedet for avstanden mellom hindring og støtfanger

Informations techniques (FR)**Principales caractéristiques**

- Kit sonore à 4 capteurs
- Barre d'attelage connectée (Commutateur Dip à l'arrière de l'unité de commande ECU)
- Hauteur de capteur réglable de 45 à 55 cm
- Fonction d'auto-test
- Capteurs 21 mm
- Option de 4 et 2 capteurs
- 2 capteurs – utilisent C et D sur l'unité de commande
- Taille d'avertisseur : 42 x 16 mm

Fiche technique

- Plage de tension de service : 12/24 volts
- Fréquence ultrasonique : 40 KHz
- Température utile de commande : -30 à +70 °C
- Plage de détection : 0,2 à 1,5 m
- Intensité nominale : 20 à 200 mA

Commutateur 1: Le système ne déclenche pas d'alarme si une barre d'attelage et une roue de secours se trouvent sur l'arrière du véhicule.

Commutateur 2: La fonction de contrôle de distance réduit la distance de détection des capteurs A et D à 1 m, à savoir 20 cm de moins que la distance initiale. L'avertisseur émet une alarme basée sur la distance arrière entre un obstacle et la barre d'attelage/roue de secours, au lieu de la distance entre l'obstacle et le pare-chocs.

Información técnica (ES)**Características clave**

- Kit acústico de 4 sensores
- Función inteligente para enganche de remolque (interruptor DIP 1 en la parte posterior de la unidad de control ECU)
- Sensor de altura ajustable 45-55 cm
- Función de autodiagnóstico
- Sensores de 21 mm
- Opción de 4 y 2 sensores
- 2 sensores – uso de C y D en la unidad de control ECU
- Tamaño de indicador acústico: 42 x 16 mm • Taille d'avertisseur : 42 x 16 mm

Características técnicas

- Campo de tensiones de trabajo: 12-24 V
- Frecuencia ultrasonora: 40 kHz
- Temperatura de trabajo del controlador: -30 °C / 70 °C
- Campo de detección: 0,2-1,5 m
- Intensidad nominal: 20-200 mA

Interruptor 1: El sistema no activa la alarma cuando hay un enganche para remolque y una rueda de repuesto en la trasera del vehículo.

Interruptor 2: La función de control de distancia reduce la distancia de detección de los sensores A y D a 1 m, lo que es 20 cm menor que la distancia original. El indicador acústico de alarma se activa en función de la distancia entre un posible obstáculo y el enganche para remolque / la rueda de repuesto, en lugar de la distancia entre el obstáculo y el paragolpes.