

ISSUE:	DRAWN BY:	CHECKED BY:	CRF No:	DATE:	DESCRIPTION:
a	MK	KB	2846	24/11/22	First Issue
b	MK	KB	2965	01/06/23	Replaced FS021 with FS081
c					
d					
e					
f					
g					
h					
i					
j					
k					
l					
m					

I3KR

KammRack

Instructions

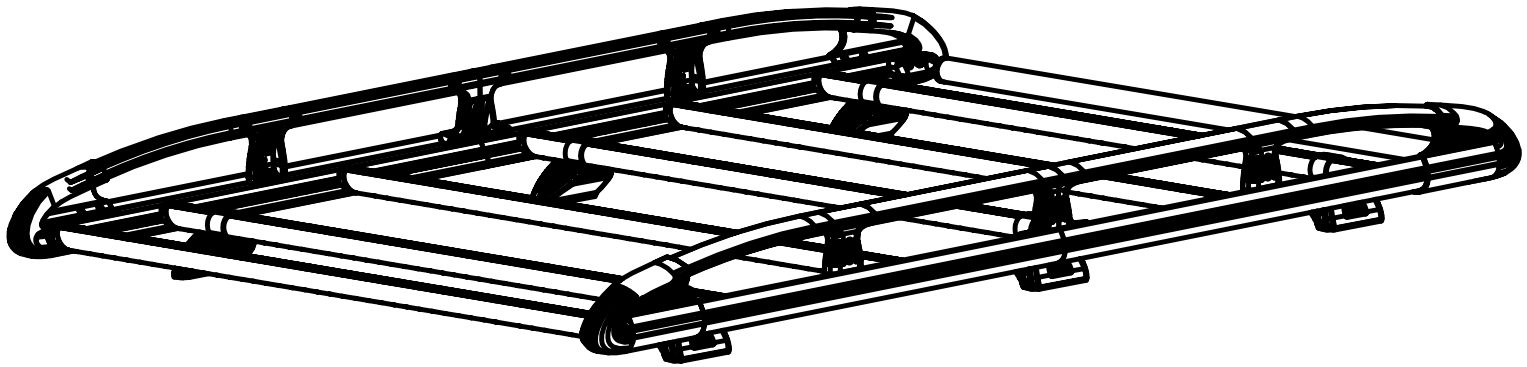

CITY CRASH (✓)

According to ISO/ PAS 11154:2006

I3KR:

IVECO Daily, 2014-

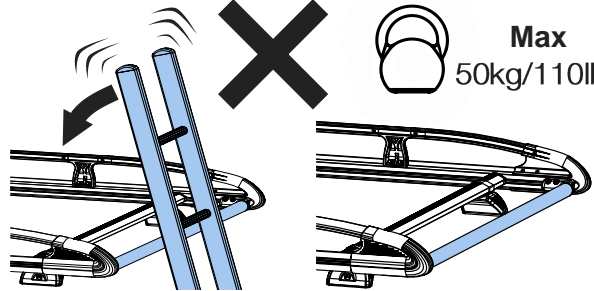
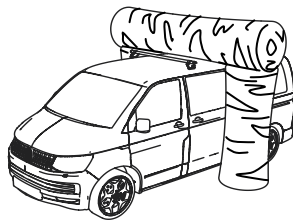
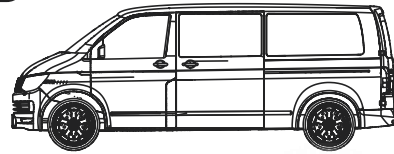

KammRack

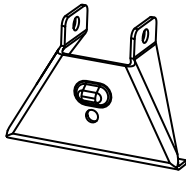

MS1632 x 6

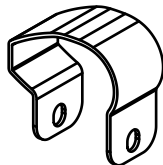

MS1142 x 6

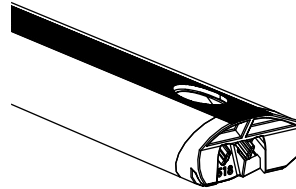

SA430

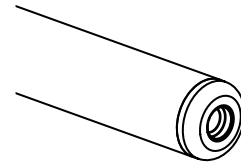

SA438 x 1

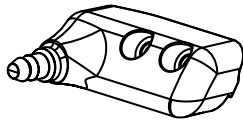

PS519 x 1

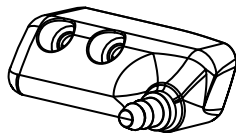

PS520 x 1

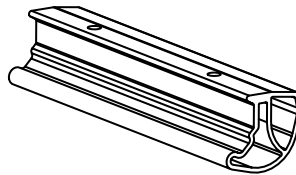

EXT15-02

LHS x 2

RHS x 2

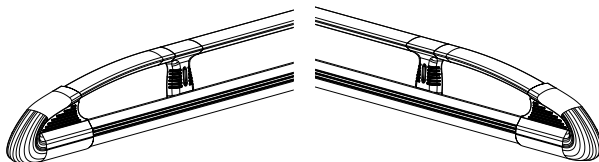

ASF x 1

Fitting Kit

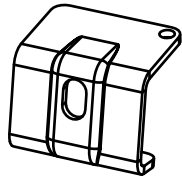

20186003 x 6

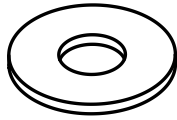

FW002 (M8) x 24

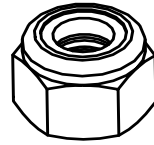

FN006 (M8) x 12



PS006-120 x 6

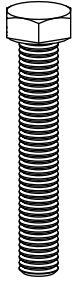

FS081 (M8 x 50) x 6

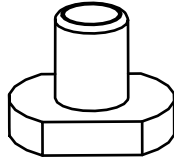

FN085 x 18



FT05 x 1

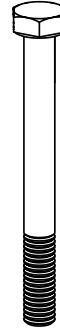

FB003 (M8 x 65) x 6

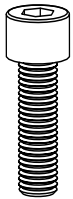

FS059 (M8 x 25) x 18



FT01 x 1

K565- Iveco Daily 2014- L1, H1, Twin Doors.

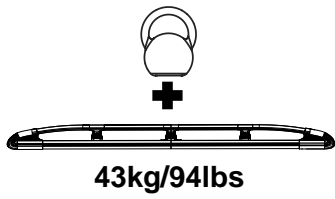

150kg
Max

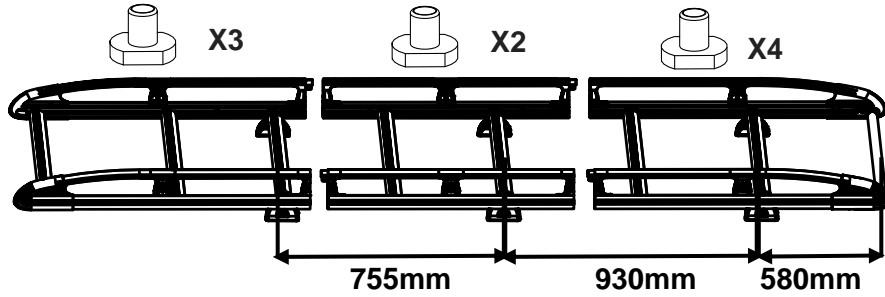
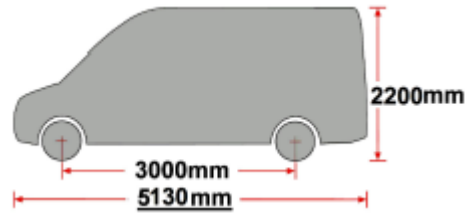

K565- Iveco Daily 2014- L2, H2, Twin Doors.

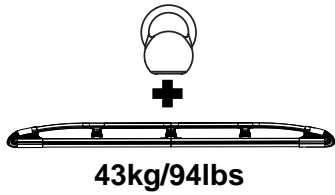

150kg
Max

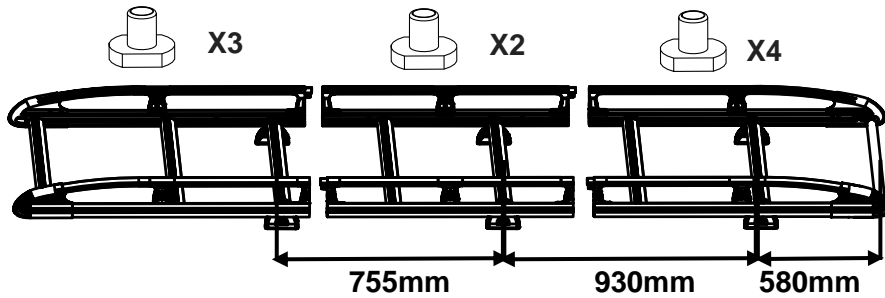
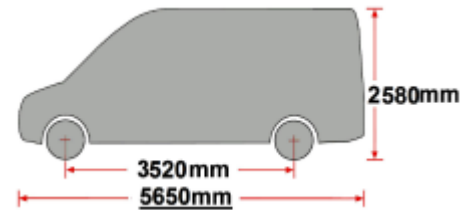

1.

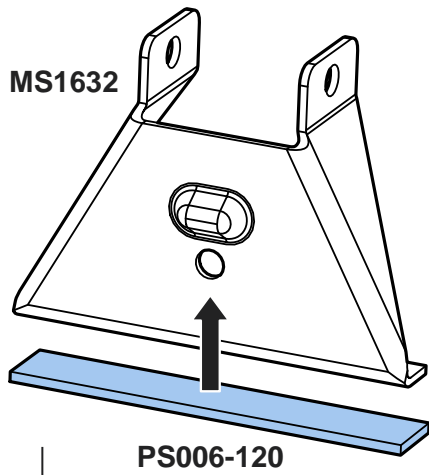

2.

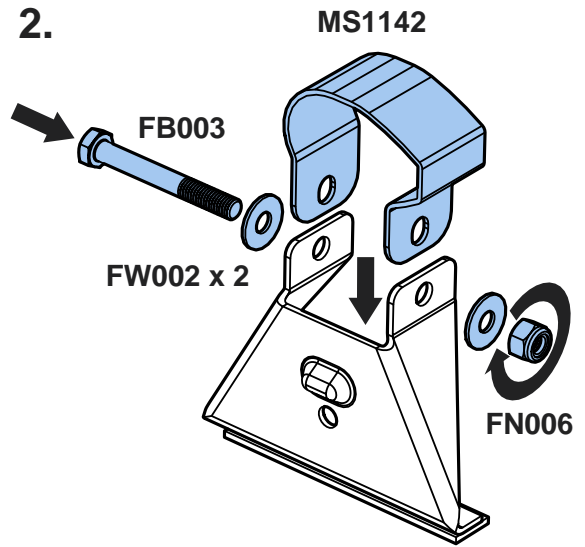

3.

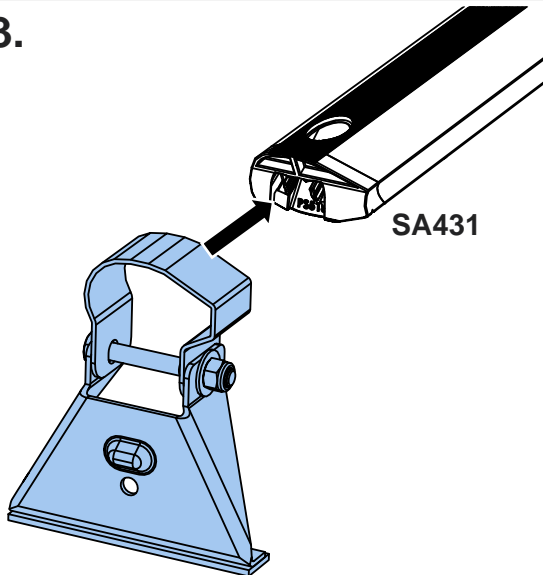

4.

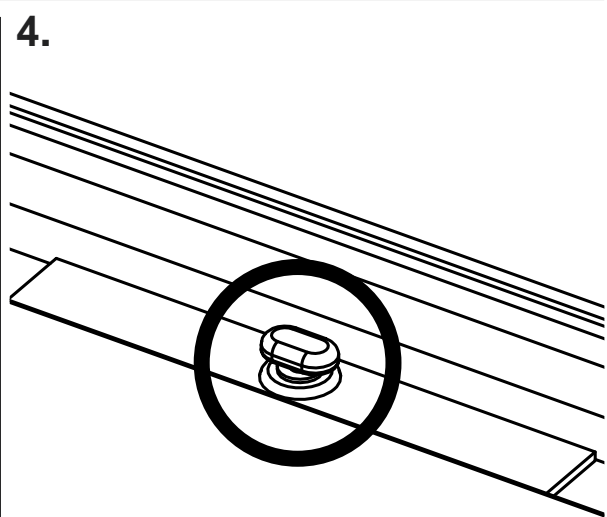

5.

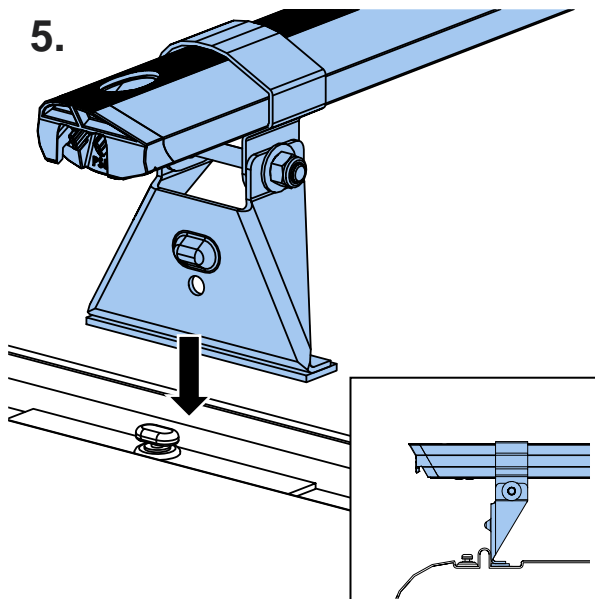

6.

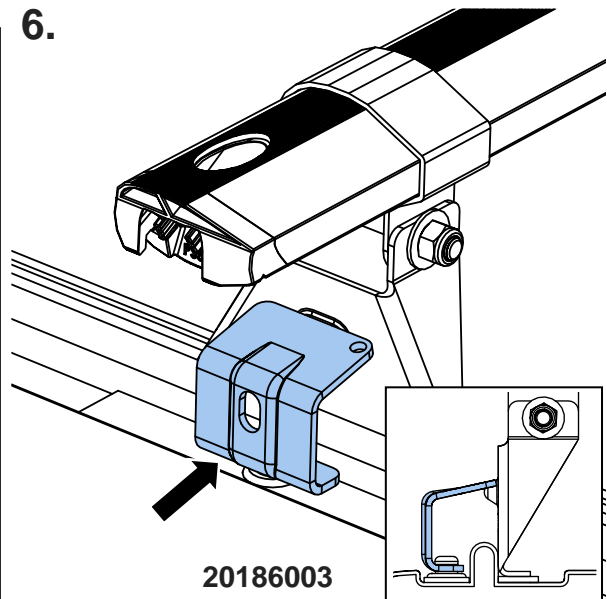

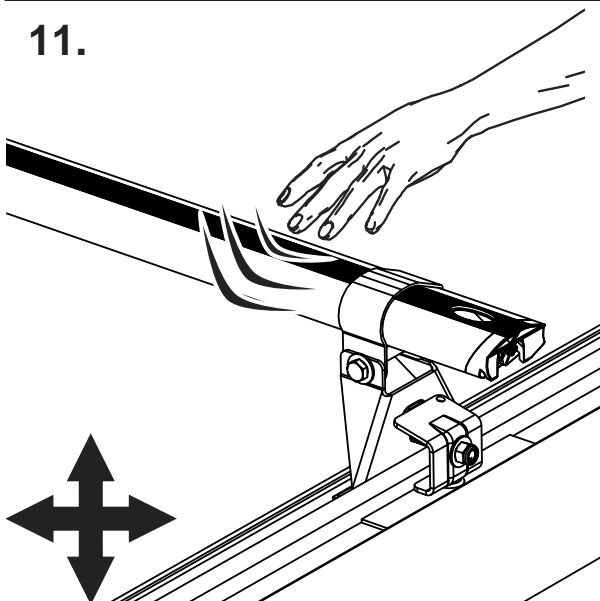
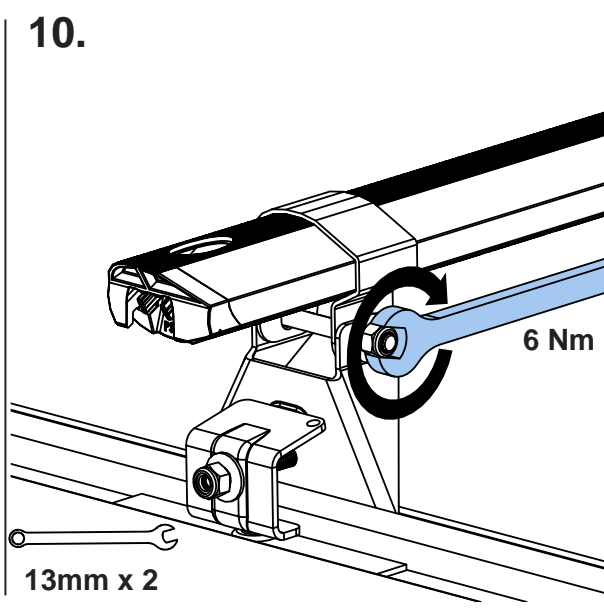
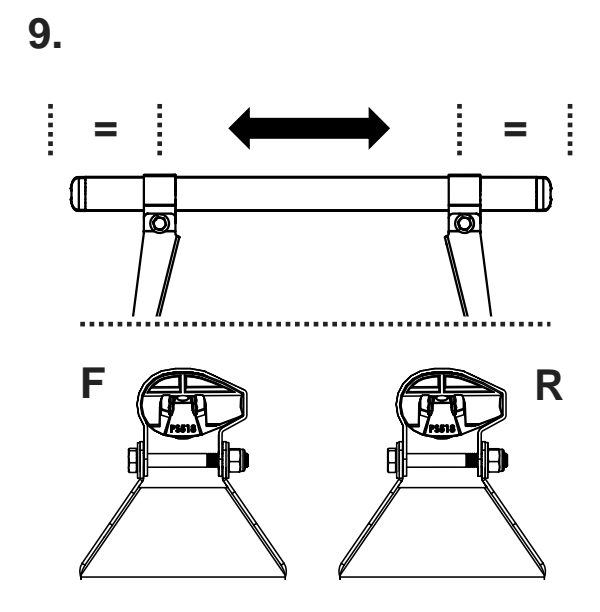
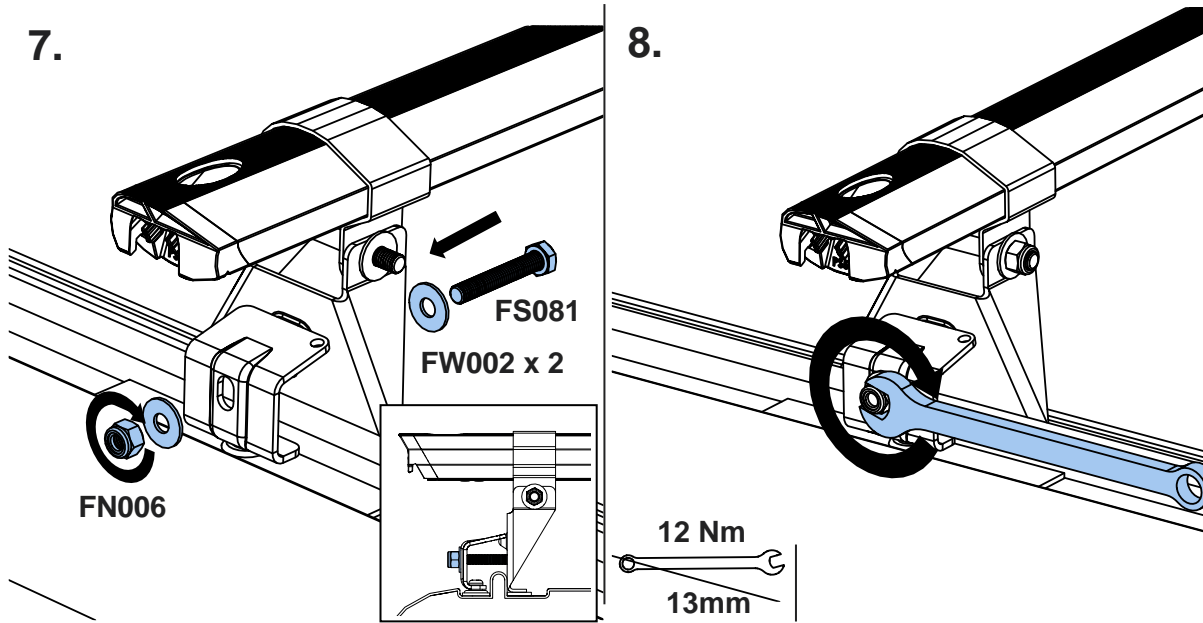

12.

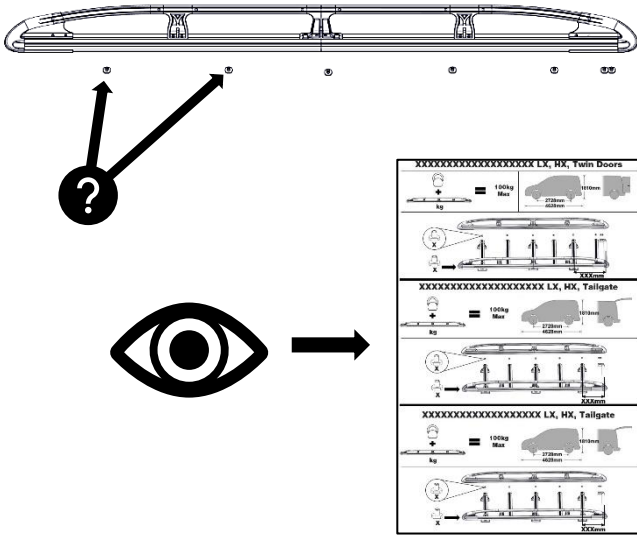

13.

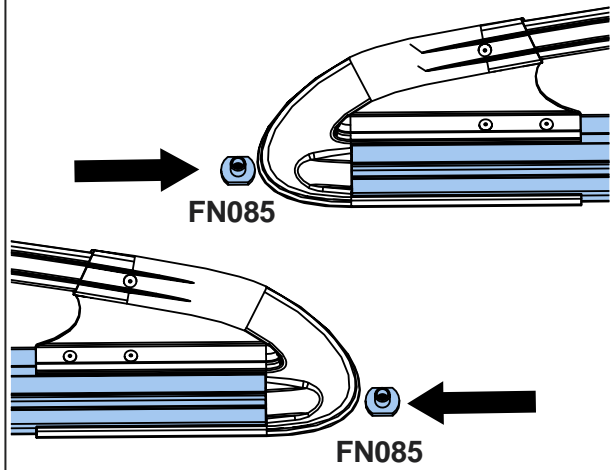

14.

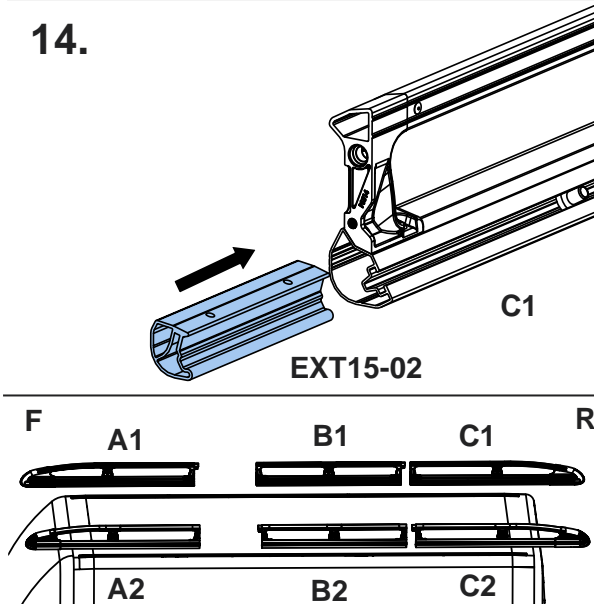

15.

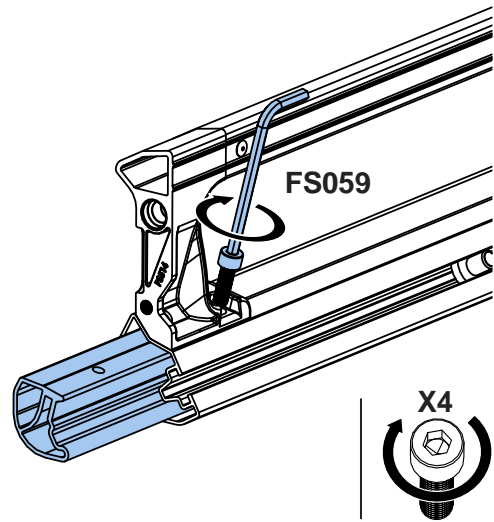

16.

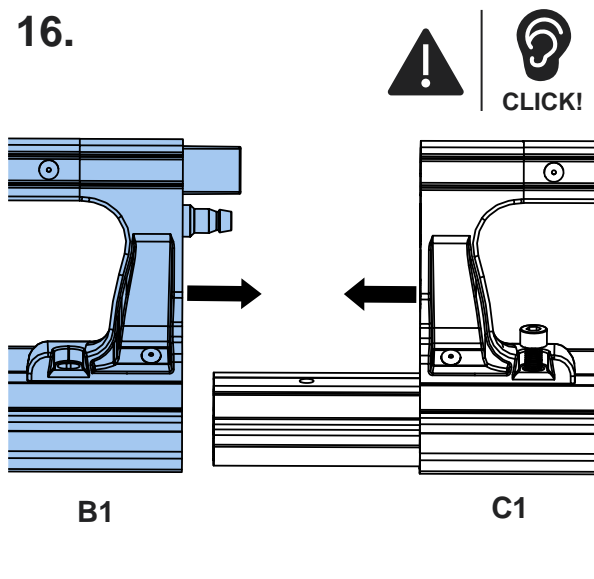

17.

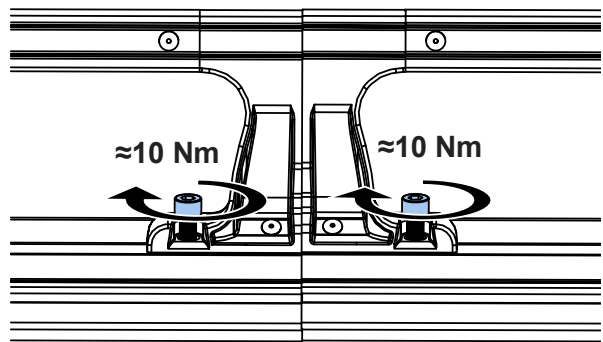

18.

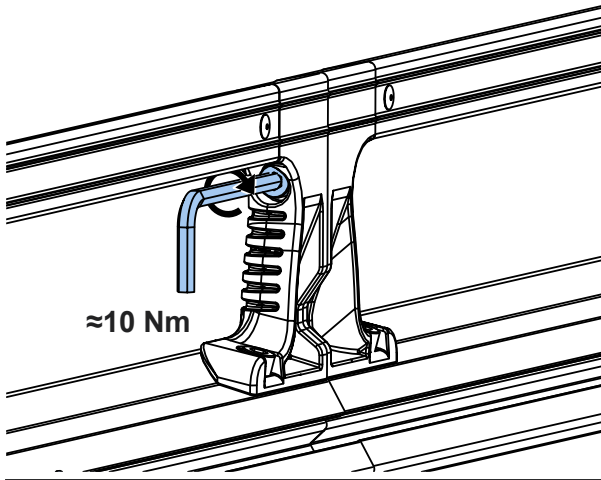

19.

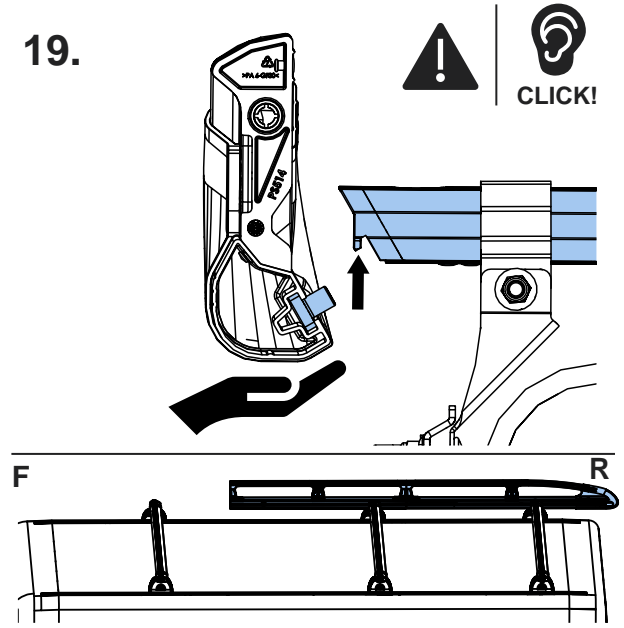

20.

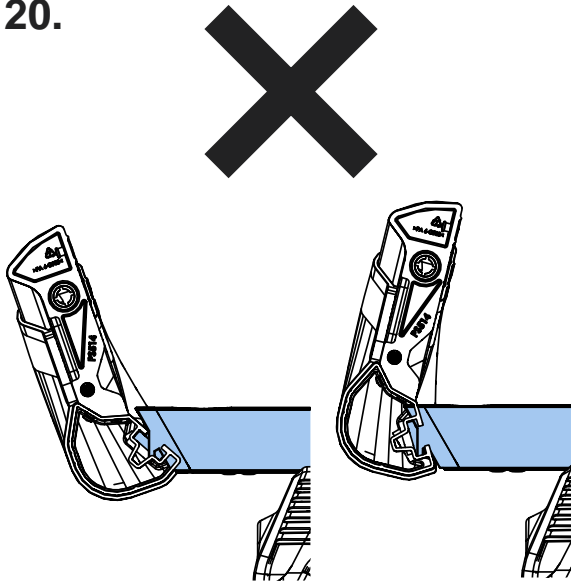

21.

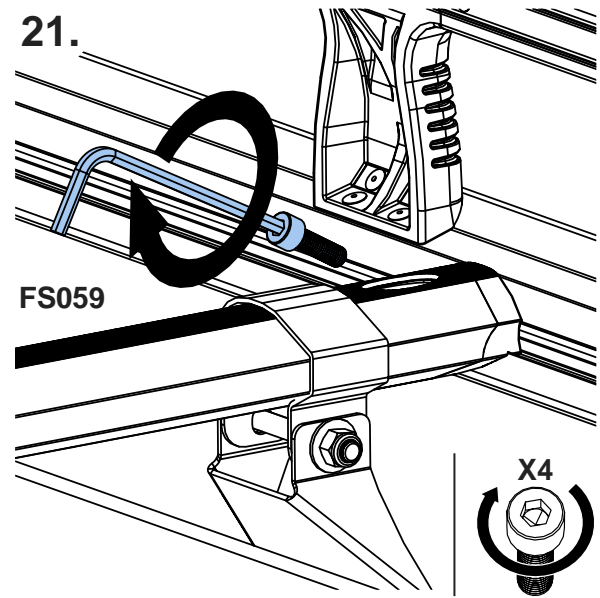

22.

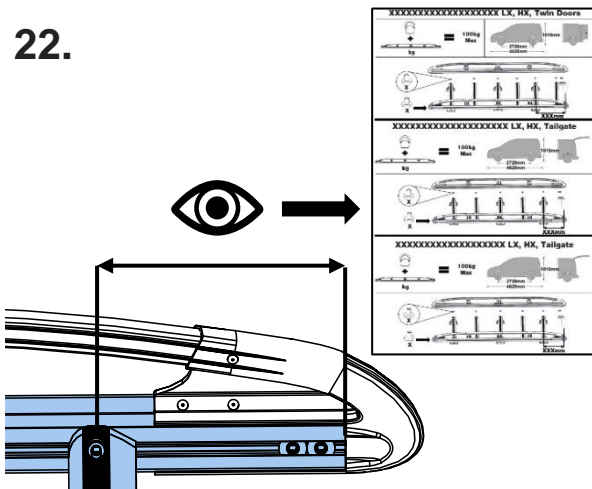

23.

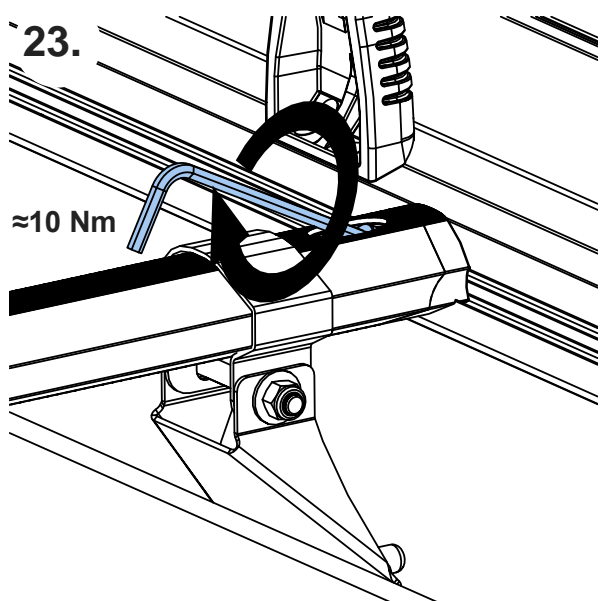

24.

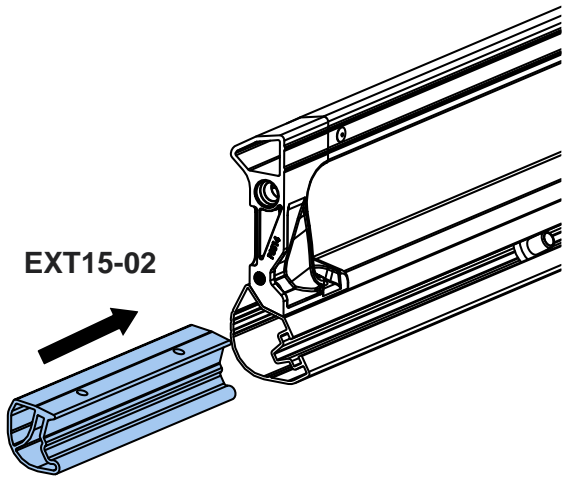

25.

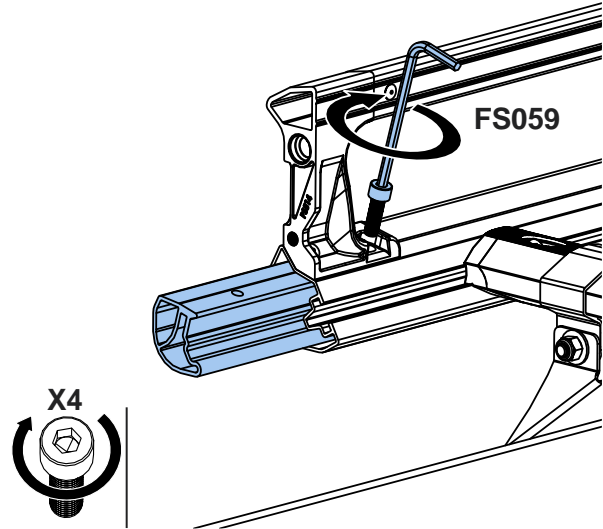

26.

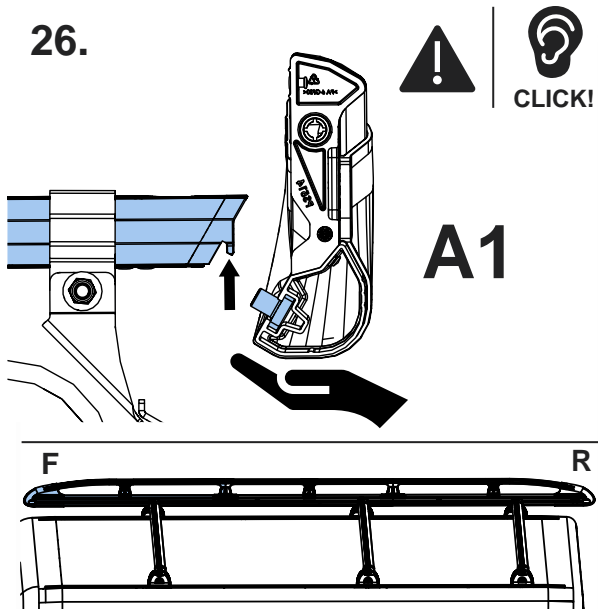

27.

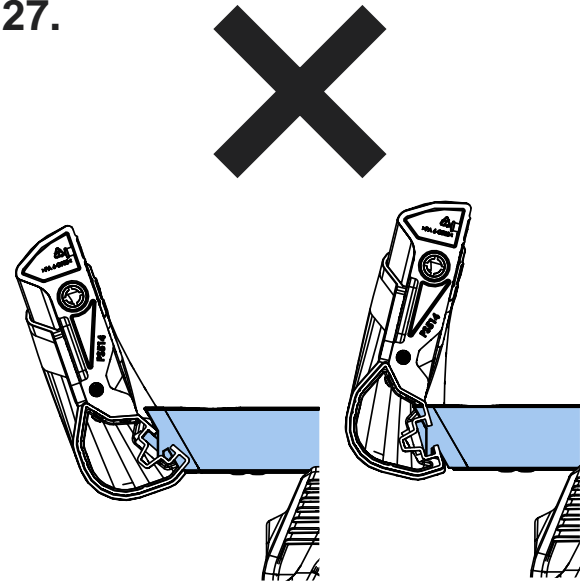

28.

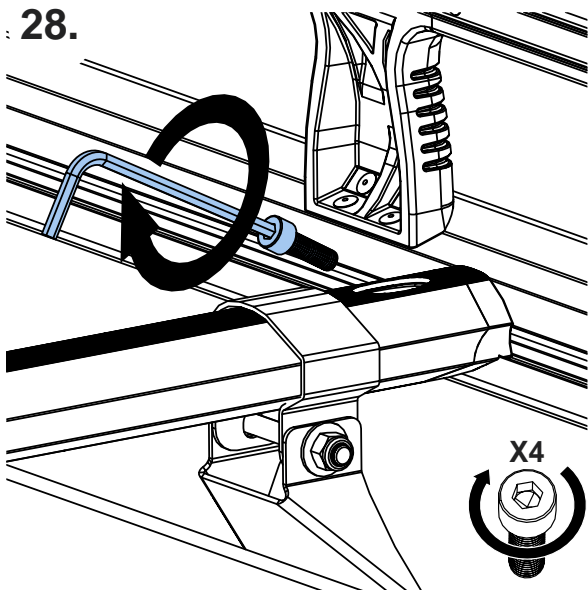

29.

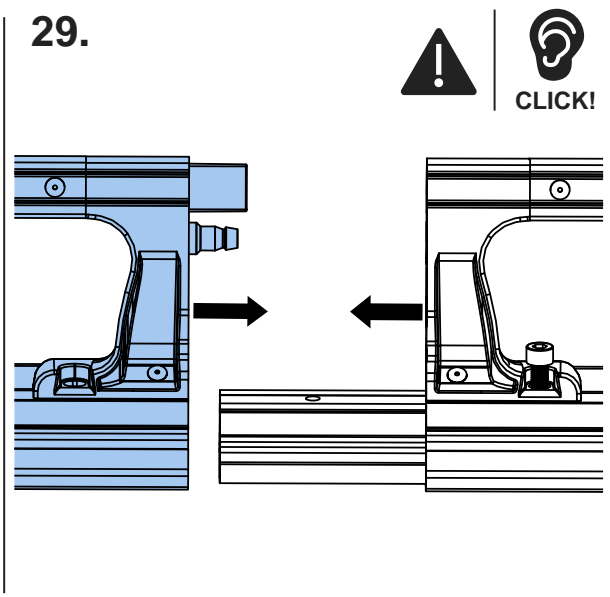

30.

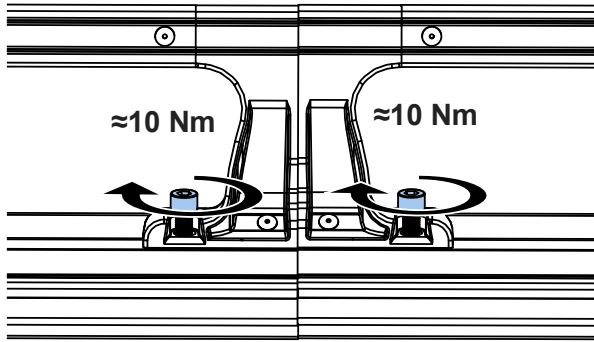

31.

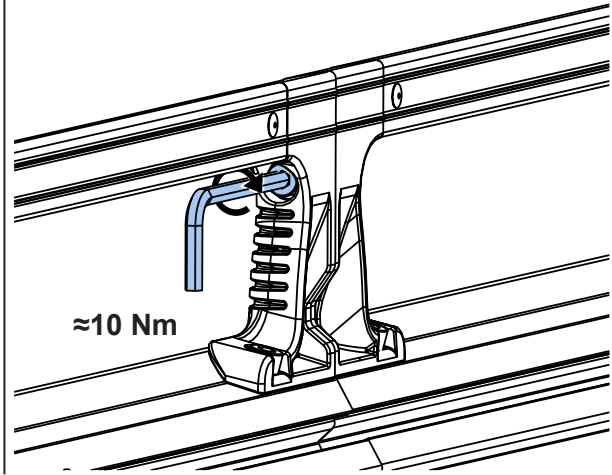

32.

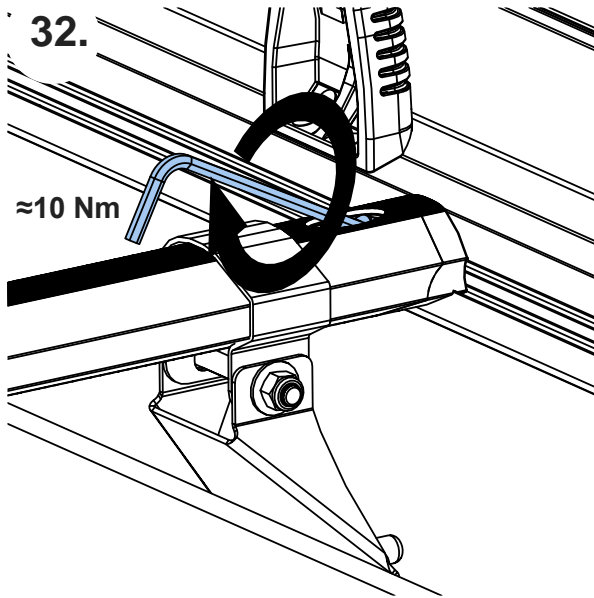

33.

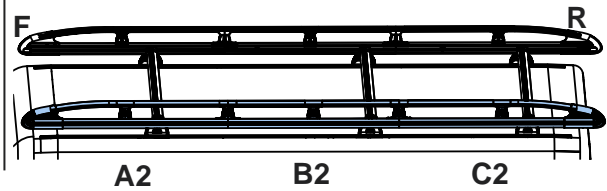
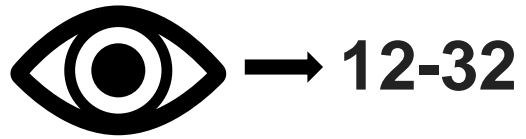

34.

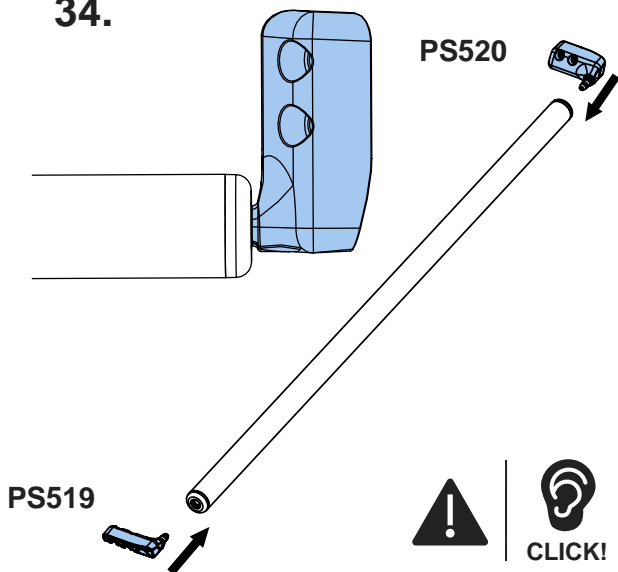

35.

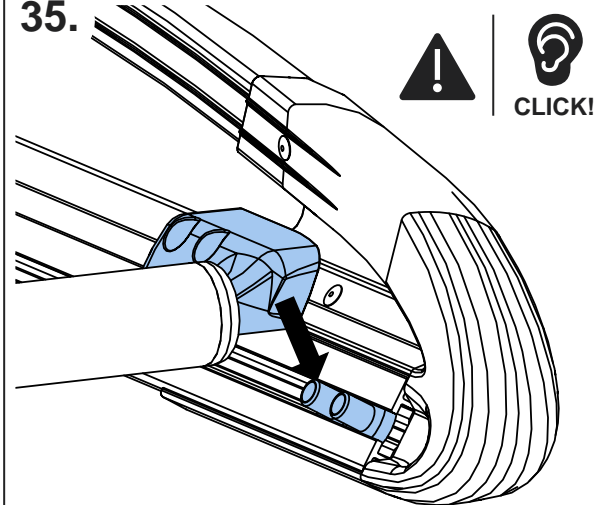

36.

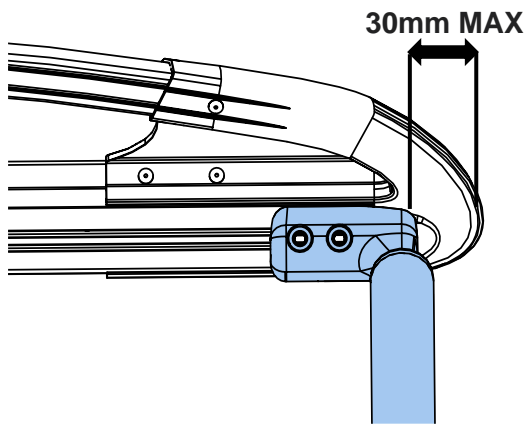

37.

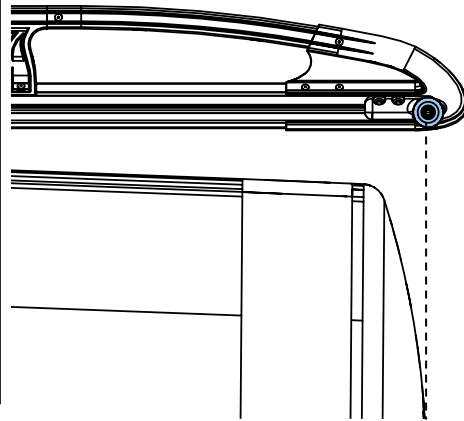

38.

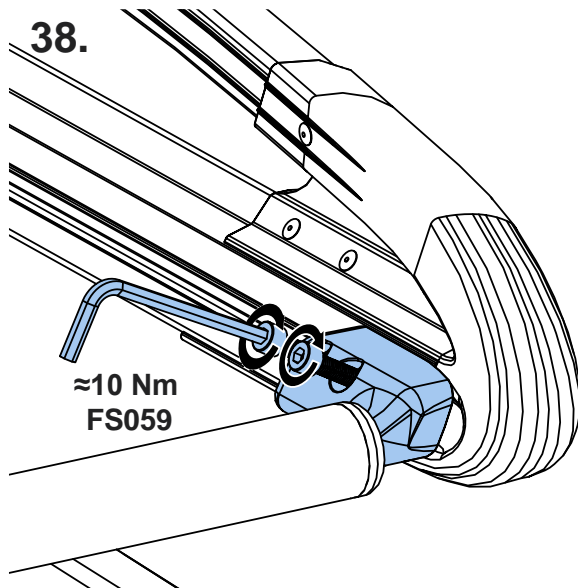

39.

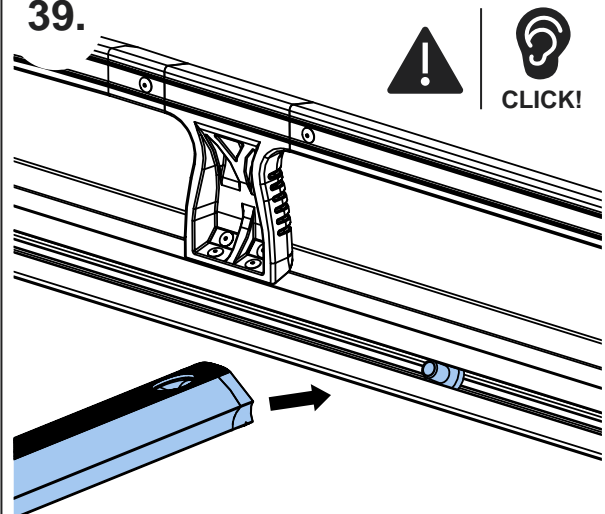

40.

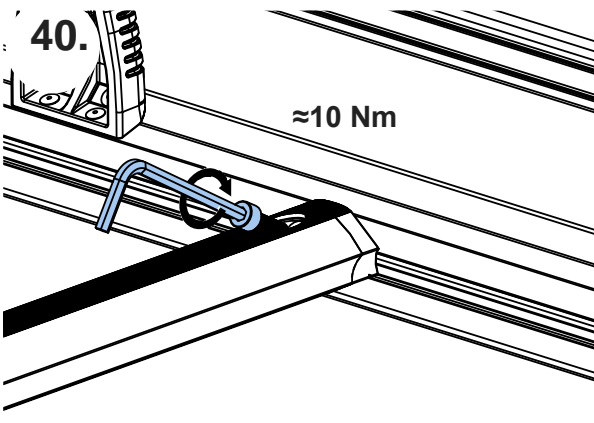

41.

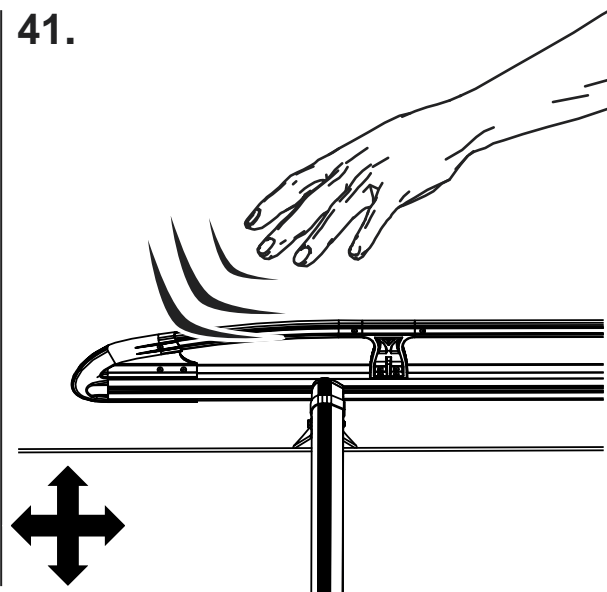

42.

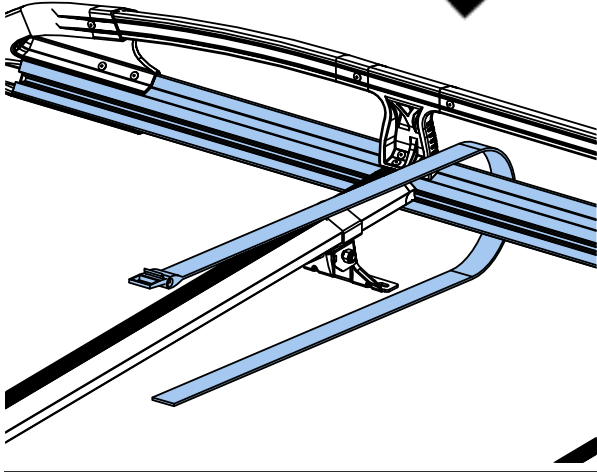

43.

