

### ROLLER ARM

Note: Only one box should be ticked

Arm	QTY	Required
140	Pair	<input type="checkbox"/>
225	Pair	<input type="checkbox"/>
250	Pair	<input type="checkbox"/>
350	Pair	<input type="checkbox"/>
375	Pair	<input type="checkbox"/>
450	Pair	<input type="checkbox"/>
500	Pair	<input type="checkbox"/>
550	Pair	<input type="checkbox"/>
570	Pair	<input type="checkbox"/>

**ROLLER ARM COMPLETED BY:** \_\_\_\_\_

### ROLLER TUBE

Note: Only one box should be ticked

Tube	QTY	Required
850	1	<input type="checkbox"/>
950	1	<input type="checkbox"/>
1000	1	<input type="checkbox"/>
1100	1	<input type="checkbox"/>
1200	1	<input type="checkbox"/>
1300	1	<input type="checkbox"/>

**ROLLER TUBE COMPLETED BY:** \_\_\_\_\_

### ROLLER FIXING KIT

Item	QTY	Checked
M8 x 75	2	<input type="checkbox"/>
M8 x 20	4	<input type="checkbox"/>
M8 'T'	2	<input type="checkbox"/>
	2	<input type="checkbox"/>

**FIXING KIT COMPLETED BY:** \_\_\_\_\_

### FOOT PAD (MAY NOT BE REQUIRED)

Note: Tick either 50mm or 75mm foot pad option if required

#### 50mm option

Item	QTY	Checked
M10 x 50mm	2	<input type="checkbox"/>
M10	4	<input type="checkbox"/>
M10 (Slim line)	4	<input type="checkbox"/>

**FOOT PAD COMPLETED BY:** \_\_\_\_\_

---

#### 75mm option

Item	QTY	Checked
M10 x 75mm	2	<input type="checkbox"/>
M10	4	<input type="checkbox"/>
M10 (Slim line)	4	<input type="checkbox"/>

**FOOT PAD COMPLETED BY:** \_\_\_\_\_

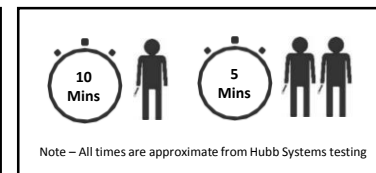
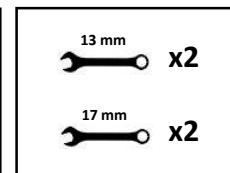
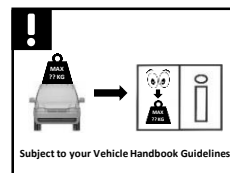
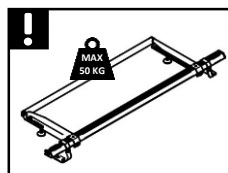
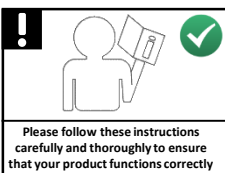

**DATE PACKED:** \_\_\_\_\_

**ORDER PACKED BY:** \_\_\_\_\_

1

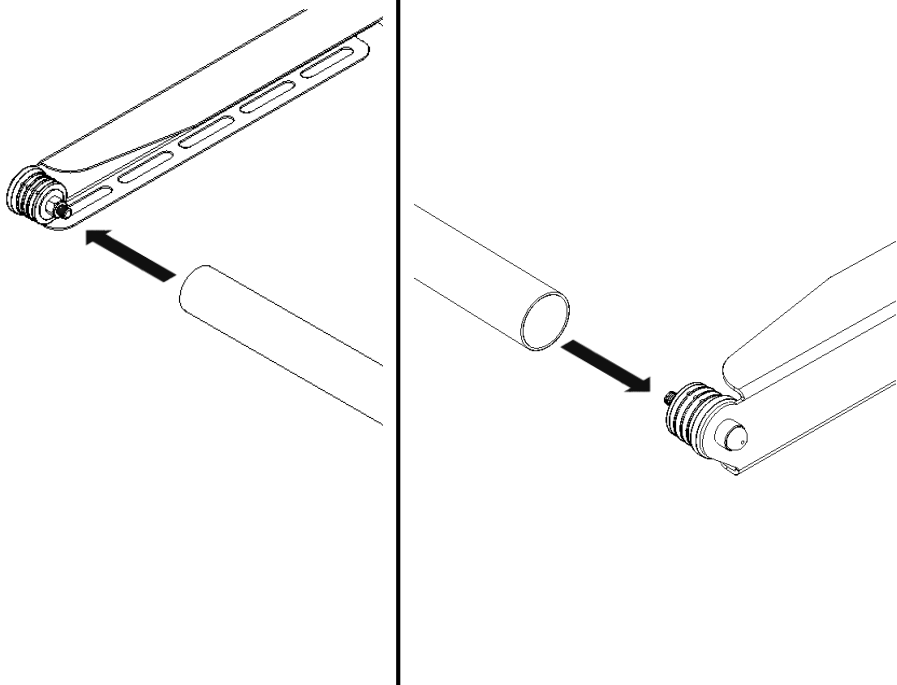

2

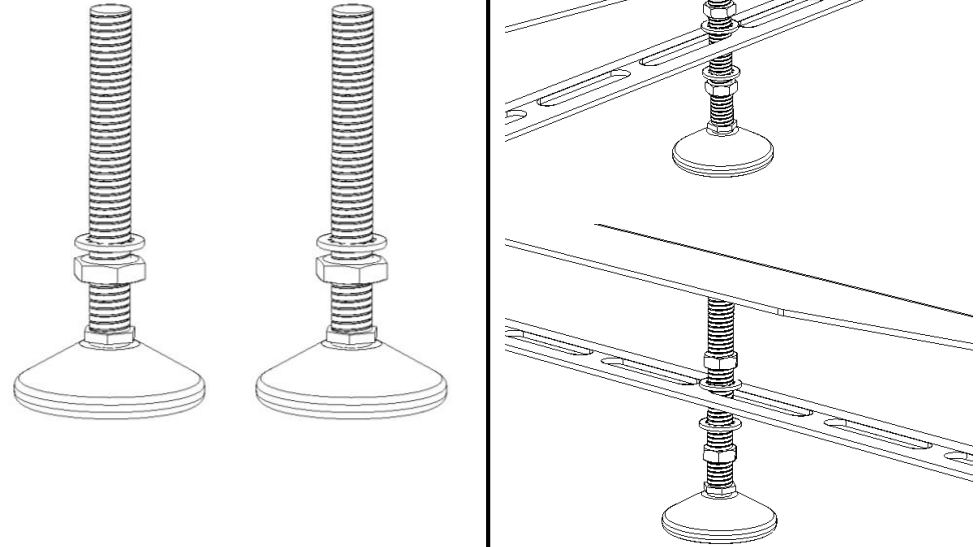

3

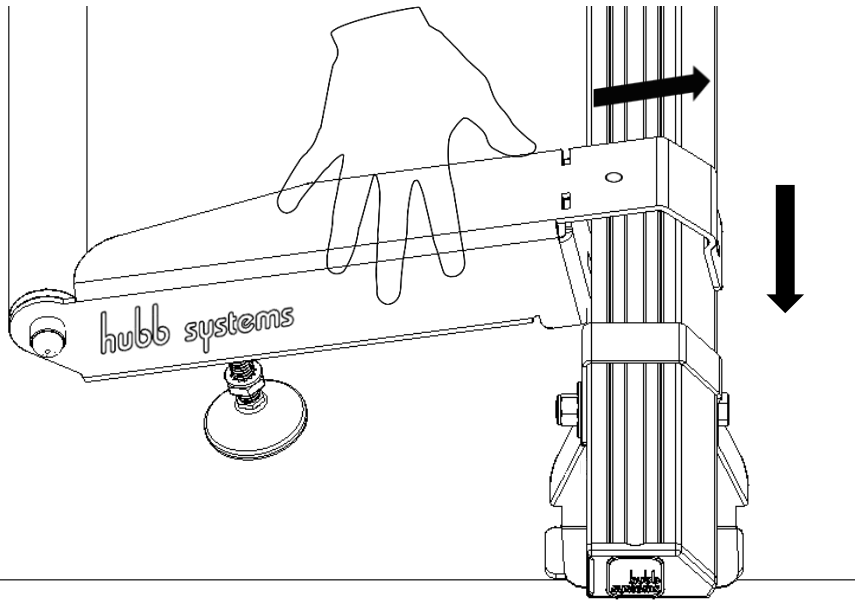

4

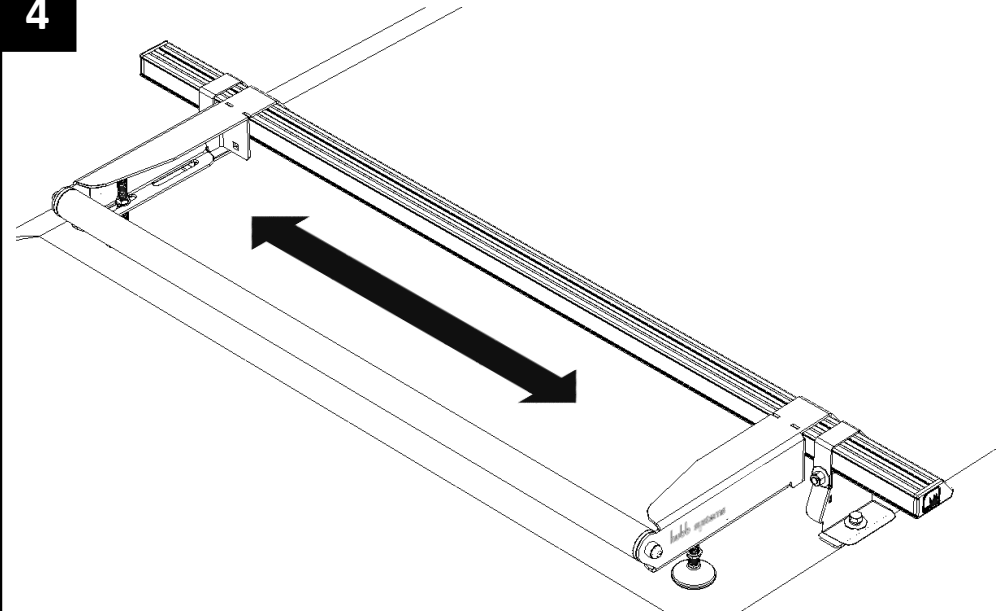

5

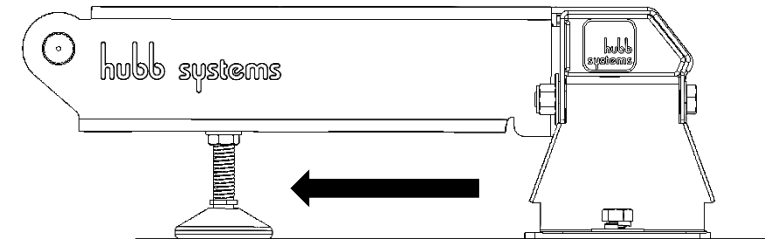
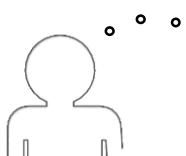
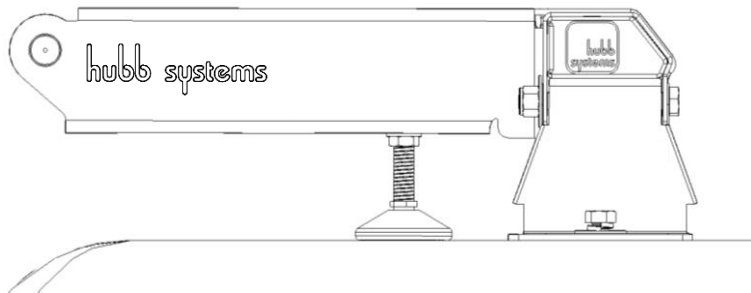

6

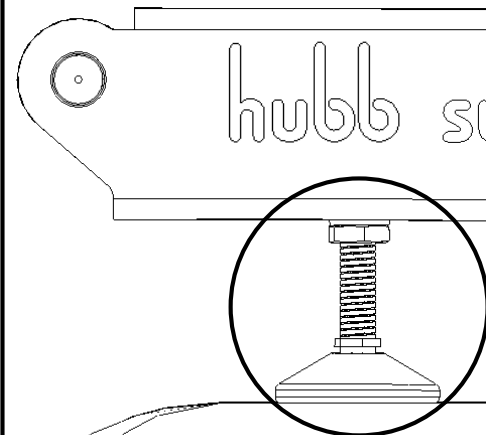
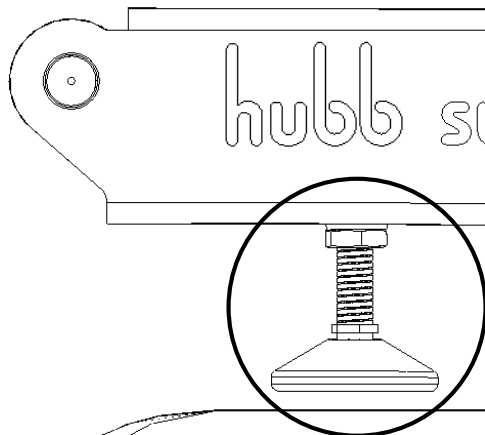

7

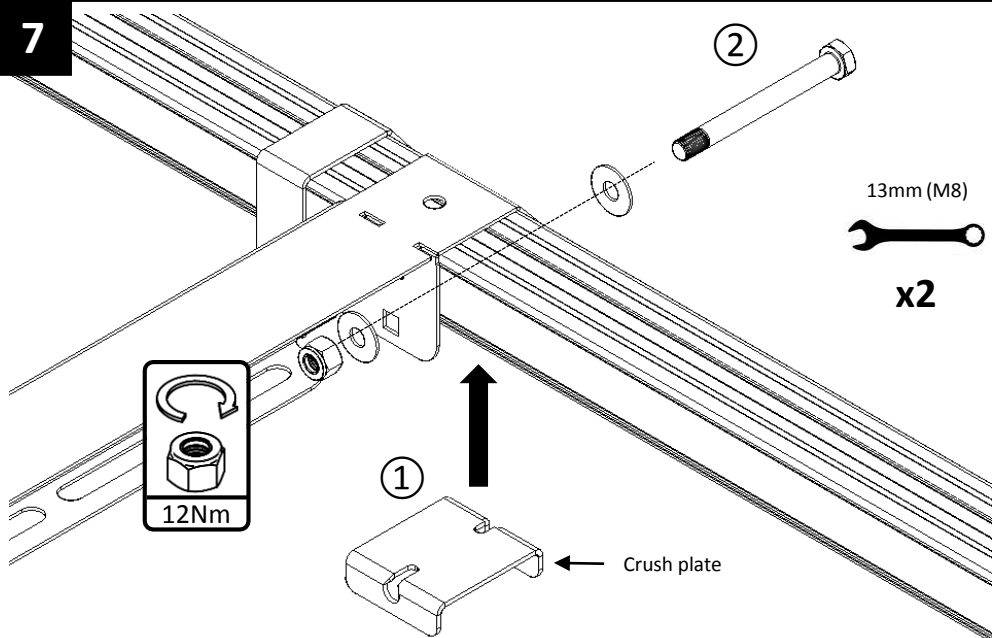

8

